



How future changes in irrigation water supply and demand affect water security in a Mediterranean catchment

J.P.C. Eekhout^{a,*}, I. Delsman^b, J.E.M. Baartman^b, M. van Eupen^c, C. van Haren^c, S. Contreras^d, J. Martínez-López^{e,f}, J. de Vente^a

^a Soil and Water Conservation Research Group, CEBAS-CSIC, Murcia, Spain

^b Soil Physics and Land Management Group, Wageningen University, Wageningen, the Netherlands

^c Wageningen Environmental Research, Wageningen, the Netherlands

^d FutureWater S.L., Cartagena, Spain

^e Department of Ecology, Faculty of Science, University of Granada, Granada, Spain

^f Instituto Interuniversitario de Investigación del Sistema Tierra en Andalucía (IISTA), University of Granada, Granada, Spain

ARTICLE INFO

Handling Editor -Dr. B.E. Clothier

Keywords:

Irrigated agriculture

Climate change

Shared Socioeconomic Pathways

Nature-based Solutions

ABSTRACT

It is likely that climate change will increase irrigation water demand and, consequently, reduces water security in the Mediterranean Basin if current irrigation supply and demand conditions are maintained. Climate change adaptation can be achieved by (1) decreasing irrigation water demand through more efficient irrigation techniques, (2) increasing irrigation water supply by adopting new technological advances, (3) converting to rainfed agriculture, and (4) implementation of Nature-based Solutions for water retention. The aim of this study was to assess the effectiveness of different combinations of these adaptation options on water security through analysis of contrasting scenarios of socio-economic development. We defined plausible scenarios of climate change, land use change and adaptation measures for an intensively irrigated catchment in south-eastern Spain under three Shared Socioeconomic Pathways (SSP), representing different storylines of socio-economic development. We considered three SSP scenarios, including the Sustainability pathway (SSP1), the Middle of the Road pathway (SSP2) and the Fossil-fueled Development pathway (SSP5). Future land use distributions were obtained with the iClue land use change model by accounting for differences in irrigation water demand and supply, resulting in a decrease (SSP1), a constant (SSP2) and an increase (SSP5) in irrigated agriculture. The impact of each scenario on a series of water security indicators was quantified using the SPHY-MMF hydrology-soil erosion model. The SSP2 scenario, which considers very limited climate change adaptation, projects the most severe impacts on water security, including an increase in plant water stress, flood discharge, hillslope erosion and sediment yield. Under SSP1, which accounts for most climate change adaptation strategies, irrigation water demand is significantly reduced due to a shift from irrigated to rainfed agriculture and the implementation of reduced deficit irrigation, while Nature-based Solutions reduce the impact on other water security indicators. Under SSP5, a conversion from rainfed to irrigated agriculture causes a significant increase in irrigation water demand, which is met by increasing irrigation water supply from desalination. SSP5 shows intermediate impacts on other water security indicators, which is explained by a strong decrease in annual precipitation. This study helps exploring how different future socio-economic pathways affect water security and thereby supports evidence-based policy development.

1. Introduction

Irrigated agriculture accounts for 85–90% of global water consumption, making it the largest consumer of water globally (Qin et al., 2019). In the Mediterranean Basin, a region that is characterized by

relatively dry Mediterranean and semi-arid climates, about 25% of the arable land surface is irrigated (MedECC, 2020). Meanwhile, the Mediterranean Basin is identified as one of the global climate change hotspots (Giorgi, 2006), characterized by a higher than average expected increase in temperature and decrease in annual precipitation

* Corresponding author.

E-mail address: joriseekhout@gmail.com (J.P.C. Eekhout).

<https://doi.org/10.1016/j.agwat.2024.108818>

Received 8 January 2024; Received in revised form 9 April 2024; Accepted 9 April 2024

Available online 16 April 2024

0378-3774/© 2024 The Author(s). Published by Elsevier B.V. This is an open access article under the CC BY-NC-ND license (<http://creativecommons.org/licenses/by-nc-nd/4.0/>).

(Dubrovský et al., 2014). This may lead to an increase in irrigation water demand of 4–18 %, if current irrigation conditions are maintained (Fader et al., 2016). Irrigated agriculture may adapt to climate change by adopting more efficient irrigation techniques (Pool et al., 2021), by switching to more drought resilient crop types (Galindo et al., 2018), or even by converting to rainfed crops (Deines et al., 2020). In addition, increased water supply may be obtained through technological innovations, like increased use of non-conventional water resources, such as desalinated seawater and treated urban waste water (Custodio et al., 2016) or by increasing the water retention in soils by implementation of Nature-based Solutions (NbS; Cohen-Shacham et al., 2016). The adoption of different combinations of such adaptation strategies depends on socio-economic developments that are crucial to consider within climate change impact assessments of Mediterranean water resources (Fischer et al., 2007; Fader et al., 2016; Harmanny and Malek, 2019).

Climate change will have a profound impact on irrigation water supply and demand, especially in the Mediterranean Basin. Decreasing precipitation accompanied with increasing temperatures will affect the two most common irrigation water sources, i.e. groundwater and surface water (Iglesias and Garrote, 2015; Qin et al., 2019), which will be affected by decreasing runoff and recharge, and increasing evaporation losses (Pulido-Velazquez et al., 2015; Mariotti et al., 2015), respectively. Moreover, groundwater reserves are also affected by overexploitation due to increasing water demands from irrigated agriculture (Wada et al., 2010; Gleeson et al., 2012; Thomas and Famiglietti, 2019), a process that is also occurring in the Mediterranean Basin (Leduc et al., 2017; Rupérez-Moreno et al., 2017; Pellicer-Martínez and Martínez-Paz, 2018). To cope with water shortages, new sources of irrigation water are being explored, such as desalination and treated waste water (Morote et al., 2017b; Mira-García et al., 2023). However, these new sources are still less cost-effective than traditional sources (Elimelech and Phillip, 2011) and come with water quality issues (Chen et al., 2013).

Meanwhile, crop water needs and related irrigation water demand are projected to increase under climate change, due to decreasing precipitation and increasing temperatures (Bakken et al., 2016; Fader et al., 2016). While some field experimental studies showed how irrigation might be affected by climate change (e.g., Soares et al., 2020; Chen et al., 2023), most studies apply hydrological and crop models for this purpose (Uniyal and Dietrich, 2021). Irrigation water demand is either estimated with a root-zone soil moisture deficit approach or a crop-specific potential evapotranspiration approach (McDermid et al., 2023). The soil moisture approach estimates the irrigation water demand by maintaining the soil moisture above a threshold, which can be related to the field capacity or other soil hydraulic properties (Allen et al., 1998). The potential evapotranspiration approach estimates the irrigation water demand as the difference between the crop-specific potential evapotranspiration and the actual evapotranspiration, under the assumption that irrigated crops transpire at the potential maximum rate (Contreras et al., 2017; McDermid et al., 2023). Using these two approaches, hydrological models are used to assess the impact of climate change on irrigation water demand, which show that decreasing precipitation may result in increasing demand (e.g., Savé et al., 2012; Grouillet et al., 2015; Bakken et al., 2016) or vice versa (e.g., Goyburo et al., 2023). Several studies showed that increasing precipitation in combination with increasing temperatures may still result in increasing demand, thereby highlighting the important contribution of temperature rise (e.g., Nam et al., 2017; Zhou et al., 2017; Rocha et al., 2020).

Technological advances may alleviate the projected increase in irrigation water demand. For instance, by the implementation of drip irrigation, which is more water efficient than traditional irrigation methods, such as sprinkler or flood irrigation (Pool et al., 2021). The irrigation infrastructure also affects water use efficiency, where pressurized irrigation systems are found to have less water leakage than open water systems (Daccache et al., 2010; Eranki et al., 2017), but may involve higher energy consumption and costs (Tarjuelo et al., 2015). The use of water efficient crops may also reduce irrigation water demand

(Galindo et al., 2018). Moreover, more efficient irrigation scheduling strategies, such as reduced deficit irrigation (Mushtaq and Moghaddasi, 2011) and enhanced monitoring of soil moisture content can decrease irrigation water demand up to 30 % (Fernández García et al., 2020). Lastly, Nature-based Solutions can be implemented, such as reduced tillage and cover crops, which may significantly increase the soil organic matter content of the soil (Almagro et al., 2016), improving its water holding capacity and, subsequently, leading to lower irrigation water demand. These NbS measures also have secondary benefits to reduce the impact on water security, such as a decrease in flood intensity and soil erosion (Chausson et al., 2020).

The expected changes in irrigation water supply and demand are not only affected by climate change. Socio-economic drivers will be equally important and may decide, for example, if novel irrigation technologies will be implemented to increase irrigation efficiency or if groundwater abstractions will be limited to natural recharge to prevent over-exploitation. The Shared Socioeconomic Pathways (SSPs; O'Neill et al., 2017) include plausible storylines of future socio-economic developments that can help to formulate future irrigation water supply and demand scenarios. The development of irrigation water supply and demand and associated climate change adaptation strategies are significantly different under SSP1 (Sustainability pathway), which, for instance, assumes a decrease in resource depletion and an increase in resource use efficiency (Mitter et al., 2020), in comparison with SSP3 (Regional Rivalry path), which assumes the opposite trends. Hence, socio-economic changes should be considered when studying the future impacts of global change on irrigation water supply and demand, and related water security issues.

Given the climate change projections and the different socio-economic pathways and their impacts on irrigation water supply and demand, it is likely that land use changes will occur to match irrigation water demand and supply. Previous research has shown that an increase in irrigation water supply, for instance, due to the construction of a reservoir or a water transfer, causes an increase in irrigated agriculture (Di Baldassarre et al., 2018; Alvarez-Rogel et al., 2020), while a decrease in irrigation water supply could lead to a decrease in irrigated agriculture (e.g., Rey et al., 2011). Similarly, an increase in irrigation efficiency, e.g. by implementing drip irrigation or by increasing the efficiency of the irrigation infrastructure, may lead to an increase in irrigated agriculture, as well (e.g. Sese-Minguez et al., 2017; Sears et al., 2018; Malek et al., 2021). Land use change models can be applied to make land use projections for the future, which may extrapolate the historical increase in irrigated area (e.g., Maeda et al., 2011; Koch et al., 2018; Halder et al., 2023) or account for the socio-economic drivers that could reverse this trend (Von Gunten et al., 2015; Nunes et al., 2017).

Climate change will affect the balance between irrigated and rainfed agriculture in the Mediterranean Basin, due to a decreasing trend in irrigation water supply (Milano et al., 2013) and an increasing trend in irrigation water demand, caused by increasing temperatures and decreasing precipitation (Fader et al., 2016). This complex interaction between climate change, agricultural land use and land management will also affect other crucial water security issues, such as plant water stress, flood intensity, soil erosion, and sediment yield. However, it is still unclear how different socio-economic pathways define climate change adaptation strategies to increase irrigation water supply (e.g. through desalination and treated waste water) and reduce irrigation water demand through technological innovations (e.g. reduced deficit irrigation and Nature-based Solutions) (Harmanny and Malek, 2019). Hence, the aim of this study is to assess the climate change adaptation potential for different pathways of socio-economic development of an intensively irrigated catchment in the south-east of Spain and assess the impacts of these scenarios on irrigated versus rainfed agriculture and water security. We determine the impacts of land use change, climate change and adaptation strategies on water security under three contrasting socio-economic scenarios (SSP1, SSP2 and SSP5), using a land use change model and a coupled hydrology-soil erosion model. We not

only assess the impacts on irrigation water supply and demand, but also assess the on- and off-site impacts using a series of relevant water security indicators, thereby obtaining a more comprehensive estimate of future impacts.

2. Material & methods

2.1. Study area

The study was performed in the Campo de Cartagena catchment (1280 km²) located in the south-east of Spain (Fig. 1). The catchment drains into the Mar Menor coastal lagoon, which has been subject to severe eutrophication in the past decades, due to nutrient-rich water input from the Campo de Cartagena catchment (Alvarez-Rogel et al., 2020). The study area is mostly characterized by gentle slopes, with some mountainous areas with steeper slopes in the south and north-western part of the catchment. The elevation ranges between sea level and 1030 masl. The catchment is characterized by a semi-arid climate, with a mean annual precipitation of 296 mm and a mean temperature of 18.5°C (1991–2020; Peral García et al., 2017).

Agriculture is the most common land use in the catchment, accounting for 65 % of the surface area (in 2020; Fig. 1c). Of the area used for agriculture, about two third is classified as irrigated agriculture (45 % of the total study area). One of the main sources of irrigation water is the Tagus-Segura Aqueduct (Fig. 1b), which was constructed at the end of the 1970's to transfer water from the Tagus River to the Segura River catchment, and played a crucial role in the development of irrigated agriculture in the study area (Alvarez-Rogel et al., 2020). Currently, more than 90 % of the irrigated agriculture uses drip irrigation (Alcon et al., 2011). Irrigated agriculture consists of irrigated tree crops (citrus), which are mostly located in the headwaters of the catchment, and irrigated horticulture (lettuce, broccoli and melons), which are mostly located in the central part and the coastal zone. Much of the irrigated crops are produced for export to European markets (Alvarez-Rogel et al., 2020).

2.2. Modelling framework

Here we introduce the overall modelling framework (Fig. 2), whereas more details about the applied scenarios, models, calibration, and data are provided in the subsections below. We determined the impacts of land use and climate change on water security under three contrasting socio-economic scenarios and corresponding adaptation measures, using a land use change model and a coupled hydrology-soil erosion model. Future irrigation water supply for each socio-economic scenario is based on an estimation of historical irrigation water supply and an interpretation of how the supply might change in the future, accounting for climate change and socio-economic projections obtained from the existing literature. The future irrigation water demand for the two irrigated crops is quantified based on the application of the hydrology-soil erosion model (SPHY-MMF; Terink et al., 2015; Eekhout et al., 2018a) under climate change, considering different irrigation techniques. Subsequently, the future land use distribution is based on the future irrigation water supply and demand and by a trend analysis of historical land use change. The future land use distribution is subsequently fed into the land use change model (iClue; Verweij et al., 2018) to obtain future spatial land use allocation maps. The projected impact of each socio-economic scenario on water security is determined with the hydrology-soil erosion model, with input from the climate change scenarios and the future land use maps, considering differences in irrigation techniques and additional climate change adaptation practices to increase water retention.

2.3. Socio-economic scenarios

We defined three socio-economic scenarios, based on three Shared Socioeconomic Pathways: SSP1 (Sustainability pathway), SSP2 (Middle of the Road pathway) and SSP5 (Fossil-fueled Development pathway). The socio-economic scenarios were used to establish changes in land use and irrigation techniques, and the implementation of Nature-based Solutions as a climate change adaptation strategy. The socio-economic scenarios were mostly based on the corresponding Eur-Agri-SSP storylines by Mitter et al. (2020), which gives a European agricultural

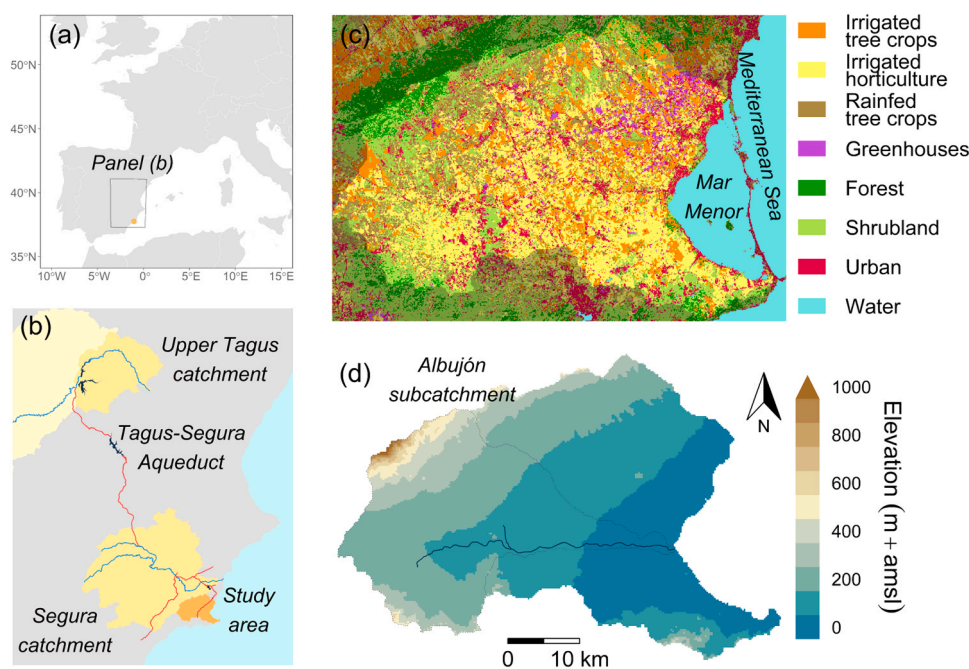

Fig. 1. (a) Location of the study area within Europe, (b) a schematic overview of the Tagus-Segura Aqueduct, including the source area (Upper Tagus catchment) and the supply area (Segura catchment and Campo de Cartagena), (c) the 2020 land use map, and (d) a Digital Elevation Model, including the location of the Albuñon subcatchment.

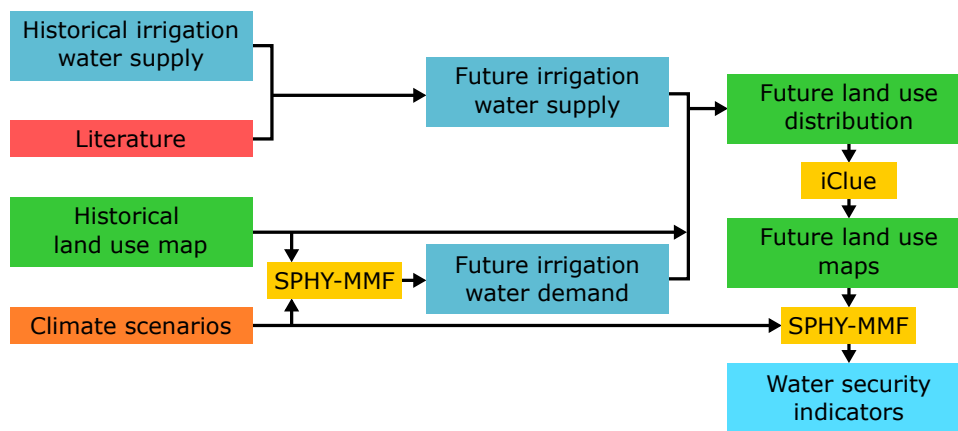

Fig. 2. Modelling framework applied in this study.

perspective on the SSP storylines by O’Neill et al. (2017). The SSP scenarios were linked to the Representative Concentration Pathways as follows: SSP1-RCP4.5, SSP2-RCP4.5 and SSP5-RCP8.5.

Irrigation water is currently supplied by five sources in the study area, i.e. groundwater abstraction, the Tagus-Segura Aqueduct, desalinated seawater, treated urban waste water and other sources. Gross groundwater abstractions amount to 104 hm³ yr⁻¹ (Jiménez-Martínez et al., 2016), from which 25 % is considered lost due to desalination of the groundwater (MITECO, 2019), resulting in 78 hm³ yr⁻¹. Water transferred from the Tagus-Segura Aqueduct has been estimated at 76.25 hm³ yr⁻¹, which is the fraction (21.8 %; MITECO, 2019) the Campo de Cartagena should receive given the average annual water supplied by the aqueduct (350 hm³ yr⁻¹; Morote et al., 2017a). Given the irrigation water supplied from desalination (8.2 hm³ yr⁻¹), treated urban waste water (24.09 hm³ yr⁻¹) and other sources (11 hm³ yr⁻¹) (MITECO, 2019), the current total irrigation water supply amounts to 197.54 hm³ yr⁻¹. See Text S1 for more details on how the amount of water originating from each irrigation water source was estimated and validated with independent irrigation water demand estimates.

The main characteristics of the three socio-economic scenarios are shown in Table 1, which will be further explained below. The change in irrigation water supplied by groundwater was based on the projected changes in resource depletion, as obtained from the Eur-Agri-SSPs by Mitter et al. (2020). For SSP1, a decrease in resource depletion is projected, therefore, under SSP1, we considered irrigation water from groundwater equal to the natural recharge of 47 hm³ yr⁻¹ (Domingo-Pinillos et al., 2018; Confederación Hidrográfica del Segura, 2023), which can be considered a climate change adaptation strategy. Accounting for the 25 % reduction rate due to desalination of the groundwater, we estimated 32.25 hm³ yr⁻¹ as groundwater supply for SSP1. An increasing trend in resource depletion is projected for SSP5, which we translated to the maximum potential increase in groundwater abstraction for the study area (+12 hm³ yr⁻¹ MITECO, 2019). The groundwater abstraction under SSP2 remained the same as under current conditions. The changes in the irrigation water supplied by the Tagus-Segura Aqueduct were based on Senent-Aparicio et al. (2021), who determined the change in water transferred under the RCP4.5 and RCP8.5 climate scenarios for the period 2040–2069, resulting in a decrease of 12.8 % (RCP4.5) and 37.1 % (RCP8.5), respectively. The change in treated urban waste water was assumed to be proportional to the change in population. We based the change in population on the projections for the Mediterranean Basin by Reimann et al. (2018), cropped to the study area. We used the 2020 population obtained from CIESIN (2018) as a reference, which resulted in population changes of -1.4 % for SSP1, +8.6 % for SSP2 and +35.5 % for SSP5. These changes coincide with the population trends projected by Mitter et al. (2020). For SSP1 and SSP2, we assumed no change in desalination and other

Table 1

Characteristics of the three socio-economic scenarios.

	SSP1-4.5	SSP2-4.5	SSP5-8.5
Irrigation water supply			
Groundwater	Natural recharge ¹	Baseline	Potential future increase ²
Tagus-Segura transfer	RCP4.5 trend ³	RCP4.5 trend ³	RCP8.5 trend ³
Desalination	Baseline	Baseline	Compensation irrigation supply and demand
Treated urban waste water	SSP1 trend ⁴	SSP2 trend ⁴	SSP5 trend ⁴
Other sources	Baseline	Baseline	Baseline
Irrigation techniques			
Irrigated tree crops	RDI	RDI	FI
Irrigated horticulture	RDI	FI	FI
Land use configuration			
Irrigated agriculture	Based on irrigation water supply and demand	Based on irrigation water supply and demand	Extrapolation of historical trend
Urban	SSP1 trend ⁴	SSP2 trend ⁴	SSP5 trend ⁴
Additional measures			
Reduced tillage/cover crops	×		
Vegetated buffer strips	×		

¹Domingo-Pinillos et al. (2018) and Confederación Hidrográfica del Segura (2023), ²MITECO (2019), ³Senent-Aparicio et al. (2021), ⁴Reimann et al. (2018)

Table 2

Precipitation sum (mm), extreme precipitation (mm) and average temperature (°C) for the reference and two future climate scenarios, indicated as a difference with respect to the reference scenario. Extreme precipitation is defined as the 95th percentile of daily precipitation, considering only rainy days (> 1 mm day⁻¹; Jacob et al., 2014). Values in bold indicate significant changes (p < 0.05) with respect to the reference scenario.

Climate signal	Reference (1991–2020)	RCP4.5 (2040–2069)	RCP8.5 (2040–2069)
Precipitation sum (mm)	295.7	-12.0 (-4.0 %)	-27.0 (-9.1 %)
Extreme precipitation (mm)	19.1	+0.2 (+1.0 %)	+0.4 (+2.0 %)
Average temperature (°C)	18.5	+0.9	+1.5

irrigation water sources, which remain 8.2 and 11 $\text{hm}^3 \text{yr}^{-1}$, respectively [Table 2](#).

For SSP5, we assume that irrigation agriculture will increase, which coincides with the increase in land productivity, further agricultural industrialization and increase of agricultural export as suggested by [Mitter et al. \(2020\)](#). Irrigated agriculture increased with 15.5 % between 2000 and 2020 (Figure S3). We linearly extrapolated this increase towards 2050, resulting in an increase of 23.3 %. This will lead to an increase in irrigation water demand, which will be compensated with water supplied from desalination as adaptation strategy, corresponding to the increase in development of technologies applied in agriculture from the Eur-Agri-SSPs ([Mitter et al., 2020](#)). Similar to SSP1 and SSP2, other irrigation water sources will remain 11 $\text{hm}^3 \text{yr}^{-1}$.

The applied irrigation techniques were also based on the Eur-Agri-SSPs from [Mitter et al. \(2020\)](#), who project an increase of resource use efficiency for SSP1 and SSP2 and no change for SSP5. To reflect these changes, we considered that reduced deficit irrigation was applied as a climate change adaptation strategy in SSP1 and SSP2, while full irrigation was applied under SSP5. Reduced deficit irrigation (RDI) is a more efficient irrigation scheduling strategy to increase resource use efficiency ([Mushtaq and Moghaddasi, 2011](#)). We adopted a relative reduction rate of 17 % with respect to full irrigation, which was based on two recent field studies conducted in the study area ([Romero-Trigueros et al., 2020](#); [Mira-García et al., 2023](#)). We implemented reduced deficit irrigation in the two main irrigated crops considered in this study, i.e. irrigated tree crops and irrigated horticulture in SSP1. In SSP2 we applied reduced deficit irrigation only in irrigated tree crops, because [Mitter et al. \(2020\)](#) suggests that resource-efficient technologies are developed at a moderate pace in SSP2 and, currently, most field based studies apply reduced deficit irrigation in tree crops only (e.g. [Romero-Trigueros et al., 2020](#); [Mira-García et al., 2023](#)).

The future irrigation water demand for the two irrigated crops was obtained by applying the SPHY-MMF model for the two climate change scenarios (RCP4.5 and RCP8.5) and the two irrigation techniques (full irrigation and reduced deficit irrigation). In these model simulations we used the 2020 land use map and determined the catchment-average irrigation water demand per hectare for the irrigated tree crops and irrigated horticulture, separately.

We assume that land use change is mostly driven by changes in irrigated water supply and demand, ultimately leading to a redistribution of land use in the study area, as was demonstrated by previous research (e.g. [Rey et al., 2011](#); [Sese-Minguez et al., 2017](#); [Di Baldassarre et al., 2018](#); [Sears et al., 2018](#); [Alvarez-Rogel et al., 2020](#); [Malek et al., 2021](#)). To obtain the total irrigated area for the three socio-economic scenarios, we divided the gross irrigation water supply by the irrigation water demand under climate change, as obtained from the SPHY-MMF model. We assumed that the ratio of irrigated tree crops vs. irrigated horticulture does not change in the future scenarios with respect to the 2020 land use map ([Fig. 1c](#)). Urban areas are projected to change according to the change in population obtained from [Reimann et al. \(2018\)](#) and [CIESIN \(2018\)](#). Irrigation is also applied in greenhouses, however, we assume no change in the area covered by greenhouses. The hydrological-soil erosion model is unable to make a reliable estimate of the irrigation water demand for greenhouses, because of the lack of reliable vegetation indices obtained from satellite images that are needed to force the model (see also below). Assuming that land covered by forest, shrubland, greenhouses and water remain constant, we used the rainfed crops to balance out the changes in irrigated crops and urban areas.

In addition to the changes in land use, in the SSP1 scenario we implemented Nature-based Solutions to increase water retention and reduce the impact on water security. According to the SSP1 narrative ([Mitter et al., 2020](#)), agricultural development is directed towards environmentally friendly processes and an increase of organic carbon in soils. This can be achieved with the implementation of different Sustainable Land Management practices (SLM; [Schwilch et al., 2012](#); [de](#)

[Vente et al., 2016](#)) or Nature-based Solutions ([Cohen-Shacham et al., 2016](#)). Our implementation of Nature-based Solutions included reduced tillage in combination with green manure (cover crops) in rainfed and irrigated agriculture. In addition, we implemented vegetated buffer strips throughout the catchment, which represent a Nature-based Solution that is currently being implemented in the study area ([BOE, 2020](#)). See Text S2 for details about the implementation of Nature-based Solutions in the SSP1 scenario.

2.4. Land use change model

We applied the iClue land use change model ([Verweij et al., 2018](#)) to obtain future land use maps for the three socio-economic scenarios. We selected the iClue model because it was best suited considering the study objectives and data input requirements. The iClue model first derives the suitability of each land use class using a step-wise regression, with the 2020 land use map ([Fig. 1c](#)) and spatially distributed variables as input. The latter included the bioclimatic variables ([Fick and Hijmans, 2017](#)), soil texture, elevation, slope, distance to urban, distance to water, soil types, among others (see [Table S4](#) for all variables). Next, the regression model was used to obtain the future land use maps, based on the land use distributions for the three scenarios.

2.5. Hydrological-soil erosion model

SPHY-MMF ([Eekhout et al., 2018a](#)) is a spatially distributed model that simulates hydrological and soil erosion processes on a cell-by-cell basis and is applied at a daily time step. Below we give a summary of the hydrological and soil erosion parts of the model, we refer to [Terink et al. \(2015\)](#) and [Eekhout et al. \(2018a\)](#), respectively, for detailed model descriptions.

The model simulates the most relevant hydrological processes, including interception, evapotranspiration, vegetation cover, irrigation water demand, surface runoff, lateral and vertical soil moisture, and water routing. The SPHY-MMF model is especially suited for the application in Mediterranean and semi-arid environments. For instance, the model accounts for infiltration excess surface runoff, a process that is associated with short intense rainfall events, which are typical for Mediterranean and semi-arid climates ([Camarasa-Belmonte and Soriano, 2014](#); [Merheb et al., 2016](#)). See Text S3 for a summary of the hydrological processes accounted for by the SPHY-MMF model. Soil erosion is determined using a daily implementation of the Morgan-Morgan-Finney model (MMF; [Morgan and Duzant, 2008](#)), which simulates the most relevant soil erosion processes, including detachment by raindrop impact, detachment by runoff and immediate deposition. Sediment is routed using a routing scheme that takes into account the transport capacity of the accumulated runoff and is calibrated using two model parameters ([Prosser and Rustomji, 2000](#)).

The SPHY-MMF model was calibrated in the Rambla de Albuñón subcatchment (44 % of the study area; [Fig. 1 \(d\)](#)), for which daily discharge observations were available. The calibration consisted of four steps in which we calibrated (1) the irrigation module, using observed irrigation water demand estimates for irrigated tree crops and irrigated horticulture in the study area ([Soto-García et al., 2013](#)), (2) the hydrological modules, using the observed daily discharge observations, for which we obtained a Kling-Gupta Efficiency (KGE) of 0.84 and a percent bias (PBIAS) of 1.1 %, (3) the soil erosion module, using soil loss estimates from [Maetens et al. \(2012\)](#), and (4) the sediment transport module, with observed sediment yield data from [García-Pintado et al. \(2007\)](#). See Text S4 for a detailed description of the calibration methods and calibration results.

2.6. Irrigation module

Here we present a new irrigation module for the SPHY-MMF model, which is based on the root-zone soil moisture deficit approach and is an

adaptation of the irrigation formulations found in Allen et al. (1998). Once the soil water content in the rootzone is determined, the model determines the irrigation water demand for the next time step. First an irrigation threshold $Irr_{\text{threshold}}$ (mm) is determined according to:

$$Irr_{\text{threshold}} = \theta_{FC} - MAD \text{ RAW} \quad (1)$$

Where θ_{FC} is the field capacity of the rootzone (mm), MAD is the management allowed depletion (-) and RAW is the readily available water (mm). The management allowed depletion MAD is a crop-specific model parameter with a tipping point at $MAD = 1$. With values of MAD below 1 no plant water stress is allowed and above 1 some plant water stress is allowed. The readily available water RAW is defined by:

$$RAW = TAW p \quad (2)$$

Where TAW is the total available water (mm) and p the depletion fraction (-). The total available water TAW is defined by:

$$TAW = \theta_{FC} - \theta_{WP} \quad (3)$$

Where θ_{WP} is the permanent wilting point of the rootzone (mm). The permanent wilting point θ_{WP} and field capacity θ_{FC} are obtained from pedo-transfer functions (Saxton and Rawls, 2006), with soil texture and organic matter content as input.

The depletion fraction is a plant specific factor and is a function of the potential evapotranspiration (Allen et al., 1998):

$$d = d_{\text{tab}} + 0.04(5 - ET_p) \quad (4)$$

Where d_{tab} is the tabular value of the depletion fraction and ET_p is the potential evapotranspiration obtained from the hydrological model. Values for d_{tab} were obtained from Allen et al. (1998). The total available water TAW , readily available water RAW and depletion factor d were already included in the model to determine the actual evapotranspiration.

The irrigation water demand Irr (mm) is determined as follows:

$$Irr = \begin{cases} Irr_{\text{threshold}} - \theta & \text{if } Irr_{\text{threshold}} \geq \theta \\ 0 & \text{if } Irr_{\text{threshold}} < \theta \end{cases} \quad (5)$$

Where θ is the actual soil water content in the rootzone (mm). The irrigation water demand is then added to the soil water balance in the next time step, once the amount of effective precipitation is determined, i.e. the precipitation minus canopy storage.

The model requires a table which specifies per irrigated crop the management allowable depletion MAD and the period of the year over which irrigation is applied (see Table S2).

2.7. Climate change scenarios

We applied the SPHY-MMF model to a reference scenario (1991–2020) and two future climate scenarios for the period 2040–2069, based on the Representative Concentration Pathway climate change scenarios, i.e. RCP4.5 and RCP8.5, which describe an emission scenario peaking in 2040 followed by a decline (RCP4.5), and an emission scenario with continuous increase in emissions throughout the 21st century (RCP8.5) (van Vuuren et al., 2011). The future period and climate change scenarios coincide with the ones used in Sent-Aparicio et al. (2021) to define the impacts on irrigation water supply from the Tagus-Segura Aqueduct. Climate data for the reference scenario were obtained from a 5-km gridded dataset from the Spanish national meteorological institute (AEMET; Peral García et al., 2017). Climate data for the future climate scenarios were obtained from nine GCM/RCM (General Circulation Model/Regional Climate Model) combinations from the EURO-CORDEX initiative (Jacob et al., 2014), with a 0.11° resolution (Table S5). The RCM data were bias-corrected using Scaled Distribution Mapping (Switanek et al., 2017), which gives the best results with respect to other bias-correction techniques applied in

the study area, especially considering representation of extreme events (Eekhout and de Vente, 2019b). Before applying bias correction, the climate model data were interpolated onto the 5-km reference climate grid, using linear and spline interpolation for precipitation and temperature, respectively.

2.8. Input data

All input maps were interpolated or resampled to the 200 m model resolution. The digital elevation model was obtained from a Spanish national LiDAR dataset (Ministerio de Fomento de España, 2015) with a 5 m resolution and interpolated using bilinear interpolation. Soil texture (clay, silt, sand) and organic matter content were obtained from the LUCDEME dataset (Faz Cano, 2003), which includes detailed soil profile data and a soil class map (1:50,000) for the Region of Murcia, where the study area is located. We aggregated the textural data per soil class, to obtain average sand, silt and clay fractions per soil class. The organic matter map was aggregated per land use class, to obtain average organic matter content per land use class, which were subsequently applied to the reference and future land use maps. All soil maps were interpolated onto the model grid using nearest neighbour interpolation. The spatially distributed rock fraction map was obtained by applying the empirical formulation from Poesen et al. (1998), which determines rock fraction based on slope gradient, from which the latter was obtained from the digital elevation model.

NDVI images were obtained from bi-monthly Moderate Resolution Imaging Spectroradiometer (MODIS; Didan, 2015) data with a 250 m resolution for the period 2001–2020. No NDVI images were available for the historical and future periods considered in this study. Therefore, we separated the NDVI data into inter- and intra-annual NDVI estimates, which were combined to obtain NDVI time series needed for the model runs. To determine the inter-annual NDVI pattern we applied a land use specific log-linear regression model based on annual precipitation and temperature time series, as described in detail in Eekhout et al. (2018b). The intra-annual NDVI pattern was obtained from the long-term average bi-monthly (16 day) NDVI for the period 2001–2020, also differentiated per land use class. The obtained NDVI maps were interpolated onto the model grid using 2D cubic spline interpolation.

2.9. Water security indicators

Water security was estimated using a series of five water security indicators (Table 3). Irrigation water demand is obtained as the sum from all irrigated agriculture in the catchment. Plant water stress is estimated by the SPHY-MMF model to determine the evapotranspiration and is used in the irrigation module to determine irrigation threshold. It indicates how much stress the plants are experiencing because of a lack of soil moisture. Flood discharge is obtained as a time series at the Rambla de Albuñón outlet to the Mar Menor coastal lagoon. The flood discharge is defined as the average of the annual maximum daily discharge over the 30-year simulation period. Hillslope erosion is obtained from the soil erosion module as the sediment taken into transport from each grid cell. Sediment yield is obtained as a time series at the Rambla de Albuñón outlet and taken as the yearly average over the 30-year simulation period.

Table 3

Water security indicators, illustrating the unit, data type and statistical treatment of the model output.

Water security indicator	Data type	Statistical treatment
Irrigation demand ($\text{hm}^3 \text{ yr}^{-1}$)	Distributed map	Annual sum
Plant water stress (-)	Distributed map	Annual average
Flood discharge ($\text{m}^3 \text{ s}^{-1}$)	Time series	Annual average maximum
Hillslope erosion ($\text{Mg km}^{-2} \text{ yr}^{-1}$)	Distributed map	Annual sum
Sediment yield (Mg yr^{-1})	Time series	Annual sum

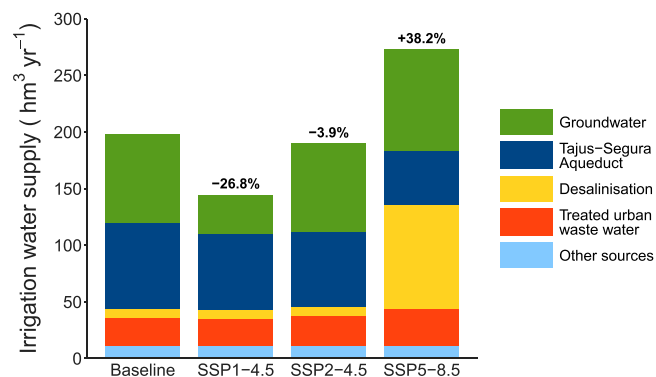

Fig. 3. Irrigation water supply (hm³ yr⁻¹) for the baseline and three SSP scenarios.

We accounted for climate model uncertainty by applying a paired U-test (Mann-Whitney-Wilcoxon test, with a significance level of 0.05). The paired U-test was used to determine the significance of the spatially distributed model outcomes, in which the pairs consisted of the model outputs for (1) the reference scenario and (2) the nine climate models.

3. Results

3.1. Irrigation water supply and demand projections

A decrease in irrigation water supply is projected for the SSP1-4.5 scenario (-26.8%), which is mostly attributed to the decrease of groundwater supply, assumed to be limited to the natural aquifer recharge in SSP1 (Fig. 3). Only minor changes to the irrigation water supply were projected for SSP2-4.5 (-3.9%), with only a moderate decrease in water supplied by the Tagus-Segura Aqueduct (-12.8%), with respect to the baseline scenario. Despite a stronger decrease in water transferred from the Tagus-Segura Aqueduct (-37.1%), a 38.2% increase in irrigation water supply is projected for the SSP5-8.5 scenario, which is mostly attributed to the substantial increase in irrigated water supplied from desalination.

We used the SPHY-MMF model to determine the irrigation water demand for the two climate change scenarios (RCP4.5 and RCP8.5) and the two irrigation techniques (full irrigation and reduced deficit irrigation) applied here (Table 4). The SSP1-4.5 scenario assumes reduced deficit irrigation for irrigated tree crops and horticulture, which results in a reduction of the irrigation water demand with respect to the baseline scenario. Most reduction in irrigation water demand is obtained for irrigated tree crops (-14.1%), while irrigated horticulture shows a moderate reduction (-7.6%). Obviously, these reductions are less than the 17.0% reduction under the calibration conditions, because of the projected decrease of precipitation and increase in temperature under the RCP4.5 climate scenario (Table 2). The SSP2-4.5 scenario only applies reduced deficit irrigation for tree crops, while full irrigation is applied for horticulture, which increases with 9.6% with respect to the baseline scenario. The impact of climate change on irrigation water demand is more obvious in the SSP5-8.5 scenario, which assumes full irrigation for both crops. Irrigation water demand for irrigated

horticulture increase most (+13.2%), while irrigated tree crops show a moderate increase (+7.8%).

3.2. Land use projections

Considering the projected changes in irrigation water supply (Fig. 3) and irrigation water demand (Table 4), we calculated how irrigated agriculture is projected to change in the study area (Fig. 4). The SSP1-4.5 and SSP2-4.5 scenarios project a decrease of irrigated area of -18.4% and -3.3%, respectively. For SSP1-4.5 the decrease in irrigation water supply is driven by the reduction of groundwater abstraction and somewhat compensated by the use of reduced deficit irrigation in all irrigated agriculture. The decrease projected for SSP2-4.5 is mostly attributed to the decrease in irrigation water supply. In scenario SSP5-8.5 an increase in irrigated agriculture is projected (+23.3%), following the historical trend in increase in irrigated agriculture.

The land use distribution was used as input into the iClue model to determine the spatial allocation of land use (Fig. 5). The land use changes projected for the SSP1-4.5 scenario are mostly characterized by a transformation from irrigated agriculture to rainfed agriculture in the headwater area of the study area. This conversion from irrigated to rainfed agriculture is mostly occurring in those areas where the opposite change occurred most recently (Figure S3). Only subtle changes in land use are projected for the SSP2-4.5 scenario, where rainfed crops are slightly increasing in the headwater area. In the SSP5-8.5 scenario, rainfed agriculture disappears in favour of irrigated agriculture and urban areas. The new urban areas are concentrated in the coastal zone and in the headwater area of the catchment.

3.3. Water security projections

We determined the impact of climate and land use change on the water security indicators using the SPHY-MMF model. Model results show that irrigation water demand decreases significantly in SSP1-4.5 (-28.2%), while it decreases only slightly in SSP2-4.5 (-3.7%), and increases significantly in SSP5-8.5 (+39.8%) (Table 5). The values

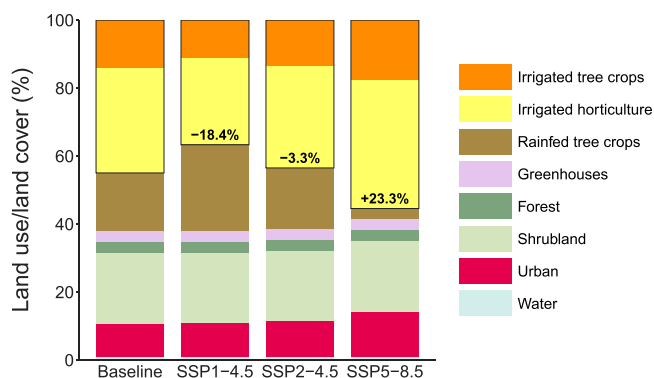

Fig. 4. Land use distribution (%) for the baseline and three SSP scenarios. The black boxes indicate the total irrigated area, where the percentage change indicates the change in irrigated area for the three scenarios with respect to the baseline scenario.

Table 4

Irrigation water demand (m³ ha⁻¹ yr⁻¹) for the baseline and three SSP scenarios. The table also shows the irrigation technique applied in each of the scenarios, where FI refers to full irrigation and RDI to reduced deficit irrigation.

Land use class	Baseline	SSP1-4.5	SSP2-4.5	SSP5-8.5
Irrigation technique	FI	RDI	FI / RDI	FI
Irrigated tree crops	4744.2	4074.8 (-14.1%)	4074.8 (-14.1%)	5113.1 (+7.8%)
Irrigated horticulture	2862.1	2645.4 (-7.6%)	3136.9 (+9.6%)	3238.6 (+13.2%)

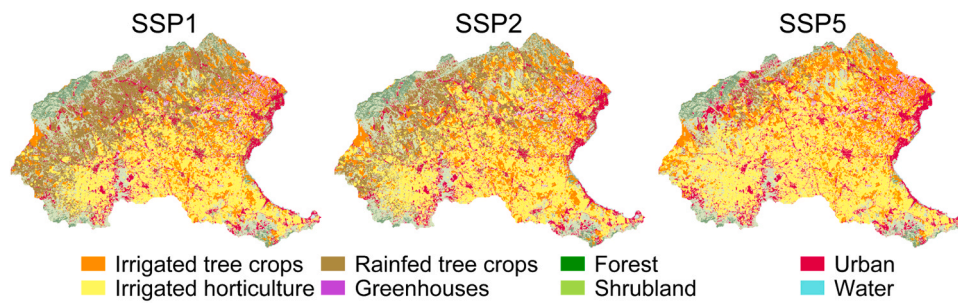

Fig. 5. Future land use maps for the three SSP scenarios as obtained from the iClue model.

Table 5

Water security indicators for the baseline scenario and change under the three future scenarios. The values shown in bold indicate a significant change with respect to the baseline scenario ($\alpha < 0.05$).

Water security indicator	Baseline	SSP1-4.5	SSP2-4.5	SSP5-8.5
Irrigation demand ($\text{hm}^3 \text{ yr}^{-1}$)	199.8	-56.4 (-28.2 %)	-7.4 (-3.7 %)	+79.6 (+39.8 %)
PWS irrigated agriculture (-)	0.31	0.06 (+18.9 %)	+0.03 (+9.6 %)	+0.01 (+2.4 %)
PWS rainfed agriculture (-)	0.62	+0.03 (+4.3 %)	+0.04 (+6.0 %)	+0.05 (+7.6 %)
Flood discharge ($\text{m}^3 \text{ s}^{-1}$)	17.2	+3.2 (+18.6 %)	+7.0 (+40.6 %)	+4.7 (+27.4 %)
Hillslope erosion ($\text{Mg km}^{-2} \text{ yr}^{-1}$)	181.4	+1.3 (+0.7 %)	+61.5 (+33.9 %)	+7.9 (+4.4 %)
Sediment yield (Mg yr^{-1})	5404.4	+2801.9 +51.8 %)	+8134.0 (+150.5 %)	+2086.5 (+38.6 %)

obtained here are similar to the changes in irrigation water supply (Fig. 3). The spatial differences in irrigation demand (Fig. 6) are the result of changes in allocation of irrigated agriculture (Fig. 5) and the applied irrigation technique (Table 4), with lower values for scenario SSP1-4.5 (reduced deficit irrigation), and higher values for the SSP5-8.5 scenario (full irrigation and more extreme climate conditions). The applied irrigation technique also affects the plant water stress under irrigated agriculture, where plant water stress increases most in SSP1-4.5 (+18.9%), under reduced deficit irrigation, while a less severe increase is projected for SSP5-8.5 (+2.4%), under full irrigation. The increase in plant water stress for rainfed agriculture shows an opposite tendency, with lower increase for SSP1-4.5 (+4.3%), because of the implementation of Nature-based Solutions, and higher increase for SSP5-8.5 (+7.6%), due to more extreme climate conditions. Flood discharge is projected to increase in all three scenarios, which is related to the projected increase in extreme precipitation (Table 2). The implementation of NbS in SSP1-4.5 causes a lower increase in flood discharge (+18.6%) than in SSP2-4.5 (+40.6%), which is explained by the improved water holding capacity of the soil, that is obtained through

an increase in organic matter and a decrease in bulk density in SSP1-4.5. The SSP5-8.5 scenario shows an intermediate increase in flood discharge (+27.4%) without implementation of NbS.

The effect of NbS is most evident considering hillslope erosion, which increases only slightly in SSP1-4.5 (+0.7%). Hillslope erosion increases most in SSP2-4.5 (+33.9%) and is most prominent in areas where more water accumulates, which is related to the increase in flood discharge in all three scenarios (Fig. 6). Despite a projected increase in extreme precipitation, the increase of hillslope erosion under SSP5-8.5 is relatively small due to a stronger decrease in total annual precipitation (Table 2). In SSP5-8.5, the increase in hillslope erosion is most evident in the northern part of the catchment, where rainfed agriculture is replaced by irrigated tree crops on steeper slopes. Sediment yield is projected to increase in all scenarios, with the highest increase projected for SSP2-4.5 (+150.5%). The increase is related to the increase in hillslope erosion and flood discharge, which increases the potential to transport sediment towards the Mar Menor coastal lagoon. Sediment yield increases less in the SSP1-4.5 scenario (+51.8%), which is related to the implementation of NbS (vegetated buffer strips), causing a decrease in hillslope erosion

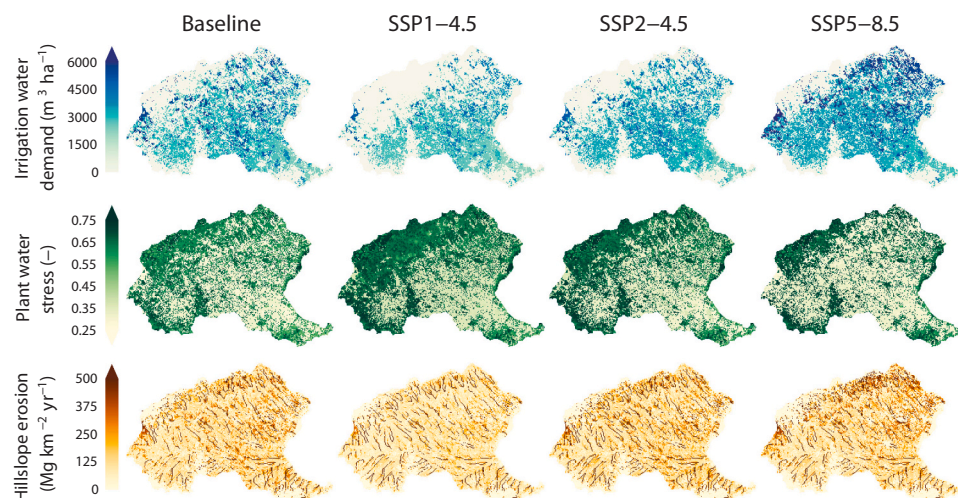

Fig. 6. Spatial SPHY-MMF model output showing the irrigation water demand ($\text{m}^3 \text{ ha}^{-1}$), plant water stress (-) and hillslope erosion ($\text{Mg km}^{-2} \text{ yr}^{-1}$).

and sediment transport. Under SSP5-8.5, sediment yield shows an intermediate increase due to the combined effect of an increased precipitation intensity and flood discharge, but a decreased total annual precipitation (Table 2).

4. Discussion

4.1. Socio-economic scenarios

In this study we projected how changes in irrigation water supply and demand affect the land use configuration under three socio-economic scenarios and evaluated the impacts of these three scenarios, and corresponding adaptation measures, on water security in a Mediterranean catchment in the south-east of Spain, that is currently characterised by large extensions of irrigated agriculture. The SSP2-4.5 scenario projects a small reduction in irrigation water supply, which led to only minor changes in the land use distribution with respect to the baseline scenario. Hence, this scenario can be viewed as a business-as-usual scenario (O'Neill et al., 2017), with small changes in land use and in which climate change adaptation is only considered by implementing reduced deficit irrigation in irrigated tree crops. Importantly, this scenario shows strong impacts on water security, reflected by the highest increases in flood discharge, hillslope erosion and sediment yield among the three scenarios, and intermediate impacts on plant water stress (Table 5). These results indicate that climate change adaptation is needed to prevent the negative impacts of climate change on water security in the study area, here assessed by considering the contrasting Sustainability (SSP1-4.5) and Fossil-fueled Development (SSP5-8.5) pathways.

Climate change adaptation can be achieved by following the Sustainability pathway (SSP1-4.5) in the study area, which assumes a significant > 25 % reduction in irrigation water supply from groundwater and from the Tagus-Segura Aqueduct, thereby strongly reducing the depletion of natural water resources. In combination with the application of reduced deficit irrigation, to increase water use efficiency, this leads to a decrease of irrigated agriculture of 18 %, which is converted to rainfed agriculture. Plant water stress for irrigated agriculture increases in this scenario, which can be attributed to the implementation of reduced deficit irrigation, in combination with increasing temperatures and decreasing annual precipitation (Table 2). However, Nature-based Solutions, as implemented in this scenario through the use of cover crops, reduced tillage, and vegetated buffer strips, lead to higher soil organic matter content, lower bulk density, increased infiltration and higher water retention on the hillslopes. Thereby, these NbS reduce the impact of climate change on plant water stress in rainfed agriculture, flood discharge, hillslope erosion and sediment yield. While these environmental benefits are directly related to socio-economic benefits (e.g. less damage from floods and droughts), there is still insufficient knowledge on all socio-economic implications of this scenario (e.g. cost-benefits of agriculture), considering also interactions with other sectors like tourism and local populations that might benefit from lower agricultural pressure on natural resources. For example, Lamas Rodríguez et al. (2023) showed how environmental degradation due agricultural effluents to the coastal area had a strong negative impact on real estate prices in the area. We coupled the SSP1 scenario to the RCP4.5 climate scenario for consistency with the RCP scenarios used in Senent-Aparicio et al. (2021). While the SSP1-RCP2.6 combination is more usual, SSP1-RCP4.5 is not an improbable SSP-RCP combination (O'Neill et al., 2020). Still, the often-used SSP1-RCP2.6 combination will likely result in an even smaller impact on water security, with (i) a smaller reduction in water transferred from the Tagus-Segura Aqueduct, (ii) a lower impact on plant water stress, due to a likely smaller reduction in annual precipitation and a smaller increase in temperature, and (iii) a smaller increase in flood discharge, hillslope erosion and sediment yield, due to a likely smaller increase in extreme precipitation. Hence, our implementation with the RCP4.5 climate scenario most likely results in a

higher impact on water security than would be the case with the RCP2.6 climate scenario.

In the Fossil-fueled Development pathway (SSP5-8.5), rainfed agriculture is converted to irrigated agriculture, leading to an increase in irrigation water demand of $79.6 \text{ hm}^3 \text{ yr}^{-1}$. The increase in irrigation water demand is partly compensated by an increase in groundwater supply (increase in resource depletion, as suggested by Mitter et al., 2020), but mostly by increased seawater desalination as adaptation strategy (increase in development of technologies applied in agriculture). The total desalination water supply under SSP5-8.5 amounts to $91.4 \text{ hm}^3 \text{ yr}^{-1}$. Current nearby desalination plants have capacities up to $80 \text{ hm}^3 \text{ yr}^{-1}$ (Morote et al., 2017b), so it is not unthinkable that additional desalination plants can be built in the future to cover the additional water demand. The area covering irrigated agriculture increases with 23.3 %, which in combination with climate change will cause an increase of almost 40 % of irrigation water demand (Table 5). Irrigated agriculture under full irrigation experiences lower plant water stress, hence, plant water stress for irrigated agriculture only marginally increases in SSP5-8.5, mainly due to rising temperature. However, this comes at the expense of the significant increase in irrigation water demand. While technological developments are expected to be able to provide this additional water volume, there is still large uncertainty regarding the feasibility and impacts on water and energy pricing and cost-benefit of the agricultural sector (e.g. Elimelech and Phillip, 2011; Morote et al., 2017a; Alcon et al., 2022). Flood discharge, hillslope erosion and sediment yield do not increase as much as in SSP2-4.5, which may be attributed to a significant decrease in precipitation sum (Table 2).

The SSP scenarios were mostly based on the Eur-Agri-SSP scenarios (Mitter et al., 2020), which indicate the direction of change of a large number of storyline elements. Other literature sources are needed to quantify the direction of change to system variables that can be used for modelling impacts, such as local studies on the impacts on irrigation water supply (e.g. Domingo-Pinillos et al., 2018; Senent-Aparicio et al., 2021; Confederación Hidrográfica del Segura, 2023) or more general studies with large-scale impacts (e.g. Reimann et al., 2018). The Eur-Agri-SSP storyline elements are subdivided into several categories, for which we focused mainly on the *Environment and natural resources* category, which includes storyline elements related to resource depletion and resource use efficiency. These storyline elements were translated to changes in groundwater abstraction and the use of different irrigation techniques. In addition, we used the *Population and urbanization* category to project changes in urban land cover. In SSP5-8.5 we also considered the *Economy* category, which suggests an increase in land productivity, here translated to the conversion of low-productive rainfed agriculture to high-productive irrigated agriculture. The other two scenarios translate equally well to the economic projections. For example, Mitter et al. (2020) suggests a decreasing trend in agricultural trade for SSP1, which corresponds to the shift from high-productive irrigated agriculture to low-productive rainfed agriculture in our SSP1-4.5 scenario. For SSP2, a constant trend in agricultural trade is suggested, which corresponds to the marginal change in agricultural practice on our SSP2-4.5 scenario. While economic trade of agricultural commodities decreases in SSP1, Mitter et al. (2020) suggests that land productivity increases because of technological progress. Plant water stress is a water security indicator that can be related to land productivity, where a higher plant water stress suggests a lower productivity (Doorenbos and Kassam, 1979; Allen et al., 1998). However, our implementation of sustainable agricultural practices in the SSP1-4.5 scenario (i.e. Nature-based Solutions and reduced deficit irrigation) has a mixed impact on productivity. Plant water stress increases for irrigated agriculture, because of a lower input of water under reduced deficit irrigation. For rainfed agriculture, plant water stress also increases slightly, but is attenuated compared to the SSP2-4.5 scenario, because of the improved soil conditions (higher organic matter content and lower bulk density). Still, climate change causes an increase in plant water

stress and likely lower crop yield (Mushtaq and Moghaddasi, 2011; Mira-García et al., 2023) in all scenarios, under rainfed and irrigated agriculture due to higher temperatures and lower annual precipitation.

The interpretation and implementation of SSP scenarios in climate change impact assessments is still an evolving topic of research. Previously (downscaled) output from global integrated assessment models (e.g. IMAGE; Stehfest et al., 2014) were used as input for hydrological or other impact models (e.g. Wijngaard et al., 2018) to define SSP scenarios, which were probably not well suited for local-scale applications, due to their coarse spatial scales and lack of local interpretation of socio-economic scenarios. In the last few years, the SSP narratives (O'Neill et al., 2017) are being made specific for certain regions (e.g. Reimann et al., 2018; Kok et al., 2019) and/or economic sectors (Mitter et al., 2020). These more specific narratives allow to develop socio-economic scenarios for local study areas, in a similar way as was performed here. We focused our socio-economic scenarios on the changes in three storyline categories (i.e. *Environment and natural resources*, *Economy*, and *Population and urbanization*), because of our focus on water demand and supply in relation to irrigated agriculture and impacts on water security. Other studies showed how many other categories (e.g. Reimann et al., 2021; Nishizawa et al., 2023) can be involved in impact assessments on other sectors, by involving local stakeholders with a broad range of expertise to define the local socio-economic scenarios (Rohat et al., 2019). In the context of this case study, it could be relevant to further assess how other potential socio-economic changes, like changes in price of electricity or agricultural produce, would affect costs and benefits of each scenario in an in-depth integrated cost-benefit analysis.

An estimation of the impact on crop yields may be an essential element of such economic analyses. Crop yield reductions are often associated with the implementation of climate change adaptation strategies, such as reduced deficit irrigation and Nature-based Solutions. Our results show that implementation of reduced deficit irrigation in the SSP1-4.5 scenario leads to a considerable higher plant water stress than the full irrigation implementation of the SSP5-8.5 scenario (Table 5). An increase in plant water stress, either because of climate change or due to the implementation of reduced deficit irrigation, is associated with a decrease in crop yield (Kang et al., 2009). Field experiments that apply reduced deficit irrigation under a 14–36 % reduction of irrigated water confirm that RDI implementation leads to a reduction in crop yield, with an average crop yield reduction of 12 % for horticultural crops (Imtiyaz et al., 2000; Kuslu et al., 2008; Cabello et al., 2009; Erdem et al., 2010; Ayas et al., 2011; Sahin et al., 2015; Barzegar et al., 2018; Patra et al., 2022; Miceli et al., 2023) and 8 % for citrus crops (Tejero et al., 2011; Romero-Trigueros et al., 2020; Panigrahi, 2023), with respect to the crop yield under full irrigation. While only quantified by a few studies, the difference in net economic return between full irrigation and deficit irrigation seems neglectable due to reduced production costs (Imtiyaz et al., 2000; Patra et al., 2022). This has also been suggested for the implementation of reduced deficit irrigation in olive orchards by Fernández et al. (2020), who concluded that RDI is the most profitable option for areas where water supply is a limiting factor, such as in the Mediterranean Basin. We implemented reduced deficit irrigation with a conservative reduction of 17 %, which will most likely lead to a reduction in crop yield, while minimum differences in net economic returns are expected because of the reduction in production costs.

The implementation of NbS, like reduced tillage, cover crops, organic amendments and vegetated buffer strips, enhance the soils water retention capacity and, therefore, have strong potential as adaptation measure to decrease flood intensity and plant water stress under drought conditions, which is expected to increase farm resilience and provide economic benefits to society (Cohen-Shacham et al., 2016). The feasibility and effectiveness of these measures to increase water retention is well demonstrated in many previous field and modelling studies (e.g. Almagro et al., 2016; Eekhout and de Vente, 2019a; Chausson et al., 2020). Moreover, our current results demonstrate that NbS significantly

reduce the impacts on most water security indicators, illustrated by the large differences between the SSP1-4.5 and SSP2-4.5 model outcomes. The mitigating impact of NbS on plant water stress, flood discharge, soil erosion and sediment yield, will certainly also have economic benefits by reducing damage from floods and droughts. Nevertheless, although NbS are often considered as more cost-effective than grey infrastructure, detailed cost-benefit studies of NbS are scarce (Vogelsang et al., 2023) and often focus on impacts on crop yield only, disregarding impacts on management costs or economic impacts related to externalities like soil erosion, flood risk, climate change mitigation, contamination and biodiversity loss. Some studies indicate positive cost-effectiveness of NbS like those applied in this study, especially when accounting for externalities, although this may require public economic support (e.g. De Leijster et al., 2020; de Groot et al., 2022) and depends on the maturing time of the NbS (Vogelsang et al., 2023). Previous studies in rainfed systems showed how some NbS (e.g. no tillage) may result in a reduction in crop yields, especially in the first years after implementation (Martin-Gorriz et al., 2020; De Leijster et al., 2020). However, other (combinations of) practices, like addition of compost and green manure, and longer term evaluations, have demonstrated equal, or slightly higher crop yields, that are less sensitive to droughts and climate variations (Almagro et al., 2016; De Leijster et al., 2020). Moreover, when NbS practices are well adapted to the local context, they have strong potential to provide a range of other ecosystem services, reducing externalities with social and economic impacts like reduction of soil erosion, flood prevention, carbon sequestration and protection of biodiversity (de Groot et al., 2022).

4.2. Irrigated agriculture under climate change

Unless irrigation efficiency is improved through reduced deficit irrigation, climate change will lead to increased irrigation water demand in the study area (Table 4), which is in agreement with the general future tendency in the Mediterranean Basin (Bakken et al., 2016; Fader et al., 2016). Plant water stress is projected to increase in irrigated crops, even under full irrigation in the SSP5-8.5 scenario (Table 5), which will likely have a negative impact on crop yield (Kang et al., 2009). Notwithstanding the impacts on crop yield, irrigation efficiency will play a key role to meet the irrigation water demand in the Mediterranean Basin. Drip irrigation is already being applied in > 90 % of the irrigated agriculture in southeast Spain (Alcon et al., 2011; Fernández García et al., 2020), hence, the potential to improve irrigation efficiency is mostly limited to the implementation of reduced deficit irrigation (Martínez-Alvarez et al., 2014; Romero-Trigueros et al., 2020; Mira-García et al., 2023). However, in many parts of the Mediterranean Basin lower efficient irrigation techniques, such as flood or sprinkler irrigation, are commonly applied (Fader et al., 2016). Hence, implementation of drip irrigation has the potential to significantly improve irrigation efficiency in these parts of the Mediterranean Basin (Malek and Verburg, 2018). However, drip irrigation is not suitable for all crop types, but is mostly restricted to orchards (e.g. citrus, olive, grape) and horticulture, i.e. the crops that are currently being cultivated in the Campo de Cartagena study area. The limited potential to implement drip irrigation in other crop types (e.g. cereal) urges to adopt soil-based adaptation strategies, such as reduced tillage and regenerative agriculture, which have generally more potential to be implemented than drip irrigation in the Mediterranean Basin (Zagaría et al., 2023) and reduce the impact of rising temperatures on plant water stress, as shown in the results of the SSP1-4.5 scenario (Table 5).

Irrigation was simulated in this study with a novel irrigation module for the SPHY-MMF model. The irrigation module was based on the root-zone soil moisture deficit approach, which adjusts the irrigation water demand based on simulated soil moisture and crop characteristics. However, it is likely that irrigation demand in the study area depends more on inter-annual changes in irrigation water supply, than on crop demand (Soto-García et al., 2013). Here we assume that the sum of

water supplied by the different irrigation water sources (Table 3) is constant throughout the simulation period. However, it is likely that inter-annual climate variation will affect water supplied by groundwater abstraction and by the Tagus-Segura Aqueduct. Ideally, the irrigation water supply in dry years should be compensated by non-conventional water sources that are unaffected by climate change, such as from desalination and treated urban waste water.

Non-conventional water sources can provide important contributions to increase water supply, but are not without problems. While desalination of seawater is steadily increasing in Spain, it is still not a cost-effective alternative to other sources, because of its high-energy demand (Elimelech and Phillip, 2011; Morote et al., 2017b). It also comes with environmental issues, especially regarding the disposal of brine as a waste product of the desalination process (Morote et al., 2017b) and the still high energy requirements and carbon footprint of desalination (Xue et al., 2023). Treated urban waste water is another important additional source, but also has quality concerns, because of the high concentration of salts, nitrogen and heavy metals (Chen et al., 2013). It is, therefore, questionable if the irrigation water demand required for SSP5-8.5 can be met at an affordable price and without undesired externalities. An approach as implemented in the SSP1-4.5 scenario, which relies less on irrigated agriculture, but more on Nature-based Solutions and efficient irrigation techniques to mitigate the negative impacts on water security, is expected to be more feasible regarding continued water supply under future global change. Further integrated cost-benefit assessments, including positive and negative externalities like environmental degradation, carbon footprints and impacts on other ecosystem services, are required to assess additional impacts and feasibility of the three socio-economic scenarios (de Groot et al., 2022).

5. Conclusions

Because of projected increase in temperature and decrease in precipitation, the Mediterranean Basin will face increasing water security issues affecting both rainfed and irrigated agriculture in the coming decades. Decreasing precipitation will cause a decrease in irrigation water supply from renewable water sources, such as surface- and groundwater sources, and increasing temperature will cause an increase in irrigation water demand. Here we show that different socio-economic pathways will lead to large differences in irrigation water supply, irrigation water demand, and impacts on water security. From the three socio-economic pathways considered here, the SSP2-4.5 scenario can be viewed as a business-as-usual scenario, without major changes in land use and only minor implementation of climate change adaptation measures in irrigated agriculture. This scenario projects the strongest negative impacts on water security for most indicators, especially regarding flood discharge, hillslope erosion and sediment yield. It is therefore indisputable that policymakers should make a decision on how to proceed towards the future.

This study presents two diverging alternatives, pursuing a Sustainability pathway (SSP1) and a Fossil-fueled Development pathway (SSP5). The SSP1-4.5 scenario provides an alternative that reduces the pressure on renewable water sources, reducing irrigated agriculture with 18 % with respect to the baseline scenario. Moreover, this scenario implements reduced deficit irrigation and Nature-based Solutions to avoid the negative impacts on water security. This would significantly decrease irrigation water demand, but comes at the price of lower specific crop yield, due to higher plant water stress, and a lower gross crop yield, due to a shift from high-productive irrigated agriculture to low-productive rainfed agriculture. However, the impacts on water security will decrease with respect to the business-as-usual scenario (SSP2-4.5), most notably for flood discharge, hillslope erosion and sediment yield. The SSP5-8.5 scenario provides an alternative that pursues an increase in agricultural trade, in which rainfed agriculture is replaced by irrigated agriculture, with the aim to increase gross crop yields from

high-productive irrigated agriculture in the study area. This would significantly increase irrigation water demand (+ 40 % with respect to the baseline scenario) and will urge a substantial increase in irrigation water supply, mainly from seawater desalination, to meet the irrigation water demand in the future, at higher economic and environmental costs. However, the SSP5-8.5 scenario also leads to decreasing impacts on water security, as compared to the SSP2-4.5 scenario. This study can provide policymakers with alternatives of how different future socio-economic pathways affect water security, considering the benefits and trade-offs for different agricultural practices. While we highlight potential impacts on crop yield between the different scenarios, further integrated economic evaluations are required to assess the feasibility and impacts for society considering costs, benefits and externalities.

CRedit authorship contribution statement

J.P.C.Eekhout: Writing – review & editing, Writing – original draft, Visualization, Software, Methodology, Investigation, Funding acquisition, Formal analysis, Conceptualization. **I.Delsman:** Methodology, Investigation, Formal analysis. **J.E.M.Baartman:** Writing – review & editing, Methodology, Conceptualization. **M.van Eupen:** Software, Methodology, Investigation. **C.van Haren:** Software, Methodology, Investigation. **S.Contreras:** Writing – review & editing, Software. **J. Martínez-López:** Writing – review & editing, Methodology, Investigation, Formal analysis, Conceptualization. **J.de Vente:** Writing – review & editing, Supervision, Project administration, Methodology, Funding acquisition, Conceptualization.

Declaration of Competing Interest

The authors declare the following financial interests/personal relationships which may be considered as potential competing interests: Joris Eekhout reports financial support was provided by Spanish Ministry of Science and Innovation. Joris de Vente reports financial support was provided by Spanish Ministry of Science and Innovation. Joris de Vente reports financial support was provided by Fundación Séneca. Joris de Vente reports financial support was provided by European Union. Javier Martínez-López reports financial support was provided by University of Granada. If there are other authors, they declare that they have no known competing financial interests or personal relationships that could have appeared to influence the work reported in this paper.

Data availability

Data will be made available on request.

Acknowledgements

We acknowledge funding through the H2020 research and innovation programme of the COASTAL project (grant agreement 773782), and funding of the THINKINAZUL (C17.I01) and AGROALNEXT (PRTR-C17. I1) projects through the Spanish Ministry of Science and Innovation with funding from NextGenerationEU (European Union) and Fundación Séneca (Region of Murcia). We acknowledge the Spanish Ministry of Science and Innovation and 'Agencia Estatal de Investigación' for funding the XTREME project (PID2019-109381RB-I00/AEI/10.13039/501100011033). Joris Eekhout was supported by a Juan de la Cierva - Incorporación fellowship (IJC2020-044636-I). Javier Martínez-López was funded by the Plan Propio de Investigación (P9) of the University of Granada. The authors thank AEMET for the data provided to carry out this work (AEMET's 5 km rainfall grid). We thank Luca Furi (University of Twente, The Netherlands) and Pieter Barneveld (Wageningen University, The Netherlands) for their contributions to the SPHY-MMF irrigation module and the implementation of vegetated buffer strips. We thank the associate editor and two anonymous reviewers for their constructive comments that improved the article considerably.

Appendix A. Supporting information

Supplementary data associated with this article can be found in the online version at [doi:10.1016/j.agwat.2024.108818](https://doi.org/10.1016/j.agwat.2024.108818).

References

- Alcon, F., De Miguel, M.D., Burton, M., 2011. Duration analysis of adoption of drip irrigation technology in southeastern Spain. *Technol. Forecast. Soc. Change* 78, 991–1001. <https://doi.org/10.1016/j.techfore.2011.02.001>.
- Alcon, F., Zabala, J.A., Martínez-García, V., Albaladejo, J.A., López-Becerra, E.I., de Miguel, M.D., Martínez-Paz, J.M., 2022. The social wellbeing of irrigation water. A demand-side integrated valuation in a Mediterranean agroecosystem. *Agric. Water Manag.* 262, 107400. <https://doi.org/10.1016/j.agwat.2021.107400>.
- Confederación Hidrográfica del Segura, Plan Hidrológico de La Cuenca Del Segura. 2022–2027, Technical Report, Confederación Hidrográfica del Segura, Murcia, Spain, 2023.
- R.G. Allen, L. Pereira, D. Raes, M. Smith, *Crop Evapotranspiration: Guidelines for Computing Crop Requirements*, Technical Report 56, FAO, 1998. <https://doi.org/10.1016/j.eja.2010.12.001>.
- Almagro, M., de Vente, J., Boix-Fayos, C., García-Franco, N., Melgares de Aguilar, J., González, D., Solé-Benet, A., Martínez-Mena, M., 2016. Sustainable land management practices as providers of several ecosystem services under rainfed Mediterranean agroecosystems. *Mitig. Adapt. Strateg. Glob. Change* 21, 1029–1043. <https://doi.org/10.1007/s11027-013-9535-2>.
- Álvarez-Rogel, J., Barberá, G.G., Maxwell, B., Guerrero-Brotos, M., Díaz-García, C., Martínez-Sánchez, J.J., Sallent, A., Martínez-Ródenas, J., González-Alcaraz, M.N., Jiménez-Cárceles, F.J., Tercero, C., Gómez, R., 2020. The case of mar menor eutrophication: state of the art and description of tested nature-based solutions. *Ecol. Eng.* 158, 106086. <https://doi.org/10.1016/j.ecoleng.2020.106086>.
- Ayas, S., Orta, H., Yazgan, S., 2011. Deficit irrigation effects on broccoli (*Brassica oleracea* L. var. *Monet*) yield in unheated greenhouse condition. *Bulg. J. Agric. Sci.* 17, 551–559.
- Bakken, T., Almestad, C., MelhuusRugelbak, J., Escobar, M., Micko, S., Alfredsen, K., 2016. Climate change and increased irrigation demands: what is left for hydropower generation? Results from two semi-arid basins. *Energies* 9, 191. <https://doi.org/10.3390/en9030191>.
- Barzegar, T., Heidaryan, N., Lofti, H., Ghahremani, Z., 2018. Yield, fruit quality and physiological responses of melon cv. Khatooni under deficit irrigation. *Advances in Hortic. Sci.* 451–458. <https://doi.org/10.13128/AHS-22456>.
- BOE, Ley 3/2020, de 27 De Julio, De Recuperación Y Protección Del Mar Menor, 2020.
- Cabello, M.J., Castellanos, M.T., Romojaro, F., Martínez-Madrid, C., Ribas, F., 2009. Yield and quality of melon grown under different irrigation and nitrogen rates. *Agric. Water Manag.* 96, 866–874. <https://doi.org/10.1016/j.agwat.2008.11.006>.
- Camarasa-Belmonte, A.M., Soriano, J., 2014. Empirical study of extreme rainfall intensity in a semi-arid environment at different time scales. *J. Arid Environ.* 100–101, 63–71. <https://doi.org/10.1016/j.jaridenv.2013.10.008>.
- Chausson, A., Turner, B., Seddon, D., Chabaneix, N., Girardin, C.A.J., Kapos, V., Key, I., Roe, D., Smith, A., Woroniecki, S., Seddon, N., 2020. Mapping the effectiveness of nature-based solutions for climate change adaptation. *Glob. Change Biol.* <https://doi.org/10.1111/gcb.15310>.
- Chen, W., Lu, S., Jiao, W., Wang, M., Chang, A.C., 2013. Reclaimed water: a safe irrigation water source? *Environ. Dev.* 8, 74–83. <https://doi.org/10.1016/j.envdev.2013.04.003>.
- Chen, H., Wu, Y.-C., Cheng, C.-C., Teng, C.-Y., 2023. Effect of climate change-induced water-deficit stress on long-term rice yield. *PLOS ONE* 18, e0284290. <https://doi.org/10.1371/journal.pone.0284290>.
- CIESIN, Gridded Population of the World, Version 4 (GPWv4): Population Count Adjusted to Match 2015 Revision of UN WPP Country Totals, Revision 11, 2018.10.7927/H4PN93PB.
- E. Cohen-Shacham, G. Walters, C. Janzen, S. Maginnis, *Nature-Based Solutions to Address Global Societal Challenges*, IUCN, Gland, Switzerland, 2016.10.2305/iucn.ch.2016.13.en.
- S. Contreras, J. Hunink, A. Alcolea, J. Jimenez-Martinez, *Cuantificación de La Descarga Subterránea al Mar Menor Mediante Modelización Hidrogeológica Del Acuífero Superficial Cuaternario*, Technical Report, FutureWater, 2017.
- Custodio, E., Andreu-Rodes, J.M., Aragón, R., Estrela, T., Ferrer, J., García-Aróstegui, J. L., Manzano, M., Rodríguez-Hernández, L., Sahuquillo, A., del Villar, A., 2016. Groundwater intensive use and mining in south-eastern peninsular Spain: hydrogeological, economic and social aspects. *Sci. Total Environ.* 559, 302–316. <https://doi.org/10.1016/j.scitotenv.2016.02.107>.
- Daccache, A., Weatherhead, K., Lamaddalena, N., 2010. Climate Change and the performance of pressurized irrigation water distribution networks under Mediterranean conditions: impacts and adaptations. *Outlook Agric.* 39, 277–283. <https://doi.org/10.5367/oa.2010.0013>.
- De Leijster, V., Verburg, R.W., Santos, M.J., Wassen, M.J., Martínez-Mena, M., de Vente, J., Verweij, P.A., 2020. Almond farm profitability under agroecological management in south-eastern Spain: accounting for externalities and opportunity costs. *Agric. Syst.* 183, 102878. <https://doi.org/10.1016/j.agsy.2020.102878>.
- Deines, J.M., Schipanski, M.E., Golden, B., Zipper, S.C., Nozari, S., Rottler, C., Guerrero, B., Sharda, V., 2020. Transitions from irrigated to dryland agriculture in the Ogallala Aquifer: land use suitability and regional economic impacts. *Agric. Water Manag.* 233, 106061. <https://doi.org/10.1016/j.agwat.2020.106061>.
- Di Baldassarre, G., Wanders, N., AghaKouchak, A., Kuil, L., Rangelcroft, S., Veldkamp, T.I. E., Garcia, M., van Oel, P.R., Breinl, K., Loon, A.F. Van, 2018. Water shortages worsened by reservoir effects. *Nat. Sustain.* 1, 617–622. <https://doi.org/10.1038/s41893-018-0159-0>.
- K. Didan, MOD13Q1 MODIS/Terra Vegetation Indices 16-Day L3 Global 250m SIN Grid V006, 2015.10.5067/modis/mod13q1.006.
- Domingo-Pinillos, J., Senent-Aparicio, J., García-Aróstegui, J., Baudron, P., 2018. Long term hydrodynamic effects in a semi-arid Mediterranean multilayer aquifer: campo de Cartagena in south-eastern Spain. *Water* 10, 1320. <https://doi.org/10.3390/w10101320>.
- J. Doorenbos, A.H. Kassam, *Yield Response to Water*. FAO Irrigation and Drainage Paper No. 33, Technical Report, FAO, Rome, Italy, 1979.
- Dubrovský, M., Hayes, M., Duce, P., Trmka, M., Svoboda, M., Zara, P., 2014. Multi-GCM projections of future drought and climate variability indicators for the Mediterranean region. *Reg. Environ. Change* 14, 1907–1919. <https://doi.org/10.1007/s10113-013-0562-z>.
- Eekhout, J.P.C., Hunink, J.E., Terink, W., de Vente, J., 2018b. Why increased extreme precipitation under climate change negatively affects water security. *Hydrol. Earth Syst. Sci.* 22, 5935–5946. <https://doi.org/10.5194/hess-22-5935-2018>.
- Eekhout, J.P.C., Terink, W., de Vente, J., 2018a. Assessing the large-scale impacts of environmental change using a coupled hydrology and soil erosion model. *Earth Surf. Dyn.* 6, 687–703. <https://doi.org/10.5194/esurf-6-687-2018>.
- Eekhout, J.P.C., de Vente, J., 2019a. Assessing the effectiveness of sustainable land management for large-scale climate change adaptation. *Sci. Total Environ.* 654, 85–93. <https://doi.org/10.1016/j.scitotenv.2018.10.350>.
- Eekhout, J.P.C., de Vente, J., 2019b. The implications of bias correction methods and climate model ensembles on soil erosion projections under climate change. *Earth Surf. Process. Landf.* 44, 1137–1147. <https://doi.org/10.1002/esp.4563>.
- Elimelech, M., Phillip, W.A., 2011. The future of seawater desalination: energy, technology, and the environment. *Science* 333, 712–717. <https://doi.org/10.1126/science.1200488>.
- Eranki, P., El-Shikha, D., Hunsaker, D., Bronson, K., Landis, A., 2017. A comparative life cycle assessment of flood and drip irrigation for guayule rubber production using experimental field data. *Ind. Crops Prod.* 99, 97–108. <https://doi.org/10.1016/j.indcrop.2017.01.020>.
- Erdem, Y., Arin, L., Erdem, T., Polat, S., Deveci, M., Okursoy, H., Gültaş, H.T., 2010. Crop water stress index for assessing irrigation scheduling of drip irrigated broccoli (*Brassica oleracea* L. var. *italica*). *Agric. Water Manag.* 98, 148–156. <https://doi.org/10.1016/j.agwat.2010.08.013>.
- Fader, M., Shi, S., VonBloh, W., Bondeau, A., Cramer, W., 2016. Mediterranean irrigation under climate change: more efficient irrigation needed to compensate for increases in irrigation water requirements. *Hydrol. Earth Syst. Sci.* 20, 953–973. <https://doi.org/10.5194/hess-20-953-2016>.
- Faz Cano, A., 2003. *El Suelo De La Región De Murcia Y Su Potencial Agrícola*. In: Esteve Selma, M., Llorens, M., Martínez Gallur, C. (Eds.), *Os Recursos Naturales De La Región De Murcia: Un Análisis Interdisciplinar*. Universidad de Murcia, Servicio de Publicaciones, Murcia, Spain, pp. 161–170.
- Fernández, J.E., Alcon, F., Diaz-Espejo, A., Hernandez-Santana, V., Cuevas, M.V., 2020. Water use indicators and economic analysis for on-farm irrigation decision: a case study of a super high density olive tree orchard. *Agric. Water Manag.* 237, 106074. <https://doi.org/10.1016/j.agwat.2020.106074>.
- Fernández García, I., Lecina, S., Ruiz-Sánchez, M.C., Vera, J., Conejero, W., Conesa, M.R., Domínguez, A., Pardo, J.J., Lélis, B.C., Montesinos, P., 2020. Trends and Challenges in Irrigation Scheduling in the Semi-arid Area of Spain. *Water* 12, 785. <https://doi.org/10.3390/w12030785>.
- Fick, S.E., Hijmans, R.J., 2017. WorldClim 2: new 1-km spatial resolution climate surfaces for global land areas. *Int. J. Climatol.* 37, 4302–4315. <https://doi.org/10.1002/joc.5086>.
- Fischer, G., Tubiello, F.N., Van Velthuisen, H., Wiberg, D.A., 2007. Climate change impacts on irrigation water requirements: effects of mitigation, 1990–2080. *Technol. Forecast. Soc. Change* 74, 1083–1107. <https://doi.org/10.1016/j.techfore.2006.05.021>.
- Galindo, A., Collado-González, J., Griñán, I., Corell, M., Centeno, A., Martín-Palomo, M., Girón, I., Rodríguez, P., Cruz, Z., Memmi, H., Carbonell-Barrachina, A., Hernández, F., Torrecillas, A., Moriana, A., Pérez-López, D., 2018. Deficit irrigation and emerging fruit crops as a strategy to save water in Mediterranean semiarid agrosystems. *Agric. Water Manag.* 202, 311–324. <https://doi.org/10.1016/j.agwat.2017.08.015>.
- García-Pintado, J., Martínez-Mena, M., Barberá, G.G., Albaladejo, J., Castillo, V.M., 2007. Anthropogenic nutrient sources and loads from a Mediterranean catchment into a coastal lagoon: Mar Menor, Spain. *Sci. Total Environ.* 373, 220–239. <https://doi.org/10.1016/j.scitotenv.2006.10.046>.
- Giorgi, F., 2006. Climate change hot-spots. *Geophys. Res. Lett.* 33, 1–4. <https://doi.org/10.1029/2006GL025734>.
- Gleeson, T., Wada, Y., Bierkens, M.F., Van Beek, L.P., 2012. Water balance of global aquifers revealed by groundwater footprint. *Nature* 488, 197–200. <https://doi.org/10.1038/nature11295>.
- Goyburo, A., Rau, P., Lavado-Casimiro, W., Buytaert, W., Cuadros-Adriazola, J., Horna, D., 2023. Assessment of present and future water security under anthropogenic and climate changes using WEAP model in the Vilcanota-Urubamba catchment, Cusco, Perú. *Water* 15, 1439. <https://doi.org/10.3390/w15071439>.
- de Groot, R., Moolenaar, S., de Vente, J., De Leijster, V., Ramos, M.E., Robles, A.B., Schoonhoven, Y., Verweij, P., 2022. Framework for integrated ecosystem services assessment of the costs and benefits of large scale landscape restoration illustrated with a case study in Mediterranean Spain. *Ecosyst. Serv.* 53, 101383. <https://doi.org/10.1016/j.ecoser.2021.101383>.

- Grouillet, B., Fabre, J., Ruelland, D., Dezetter, A., 2015. Historical reconstruction and 2050 projections of water demand under anthropogenic and climate changes in two contrasted Mediterranean catchments. *J. Hydrol.* 522, 684–696. <https://doi.org/10.1016/j.jhydrol.2015.01.029>.
- Halder, S., Das, S., Basu, S., 2023. Use of support vector machine and cellular automata methods to evaluate impact of irrigation project on LULC. *Environ. Monit. Assess.* 195, 3. <https://doi.org/10.1007/s10661-022-10588-6>.
- Harmanny, K.S., Malek, Z., 2019. Adaptations in irrigated agriculture in the Mediterranean region: an overview and spatial analysis of implemented strategies. *Reg. Environ. Change* 19, 1401–1416. <https://doi.org/10.1007/s10113-019-01494-8>.
- Iglesias, A., Garrote, L., 2015. Adaptation strategies for agricultural water management under climate change in Europe. *Agric. Water Manag.* 155, 113–124. <https://doi.org/10.1016/j.agwat.2015.03.014>.
- Imtiyaz, M., Mgadla, N.P., Manase, S.K., Chendo, K., Mothobi, E.O., 2000. Yield and economic return of vegetable crops under variable irrigation. *Irrig. Sci.* 19, 87–93. <https://doi.org/10.1007/s002710050005>.
- Jacob, D., Petersen, J., Eggert, B., Alias, A., Christensen, O.B., Bouwer, L.M., Braun, A., Colette, A., Déqué, M., Georgievski, G., Georgopoulou, E., Gobiet, A., Menut, L., Nikulin, G., Haensler, A., Hempelmann, N., Jones, C., Keuler, K., Kovats, S., Kröner, N., Kotlarski, S., Kriegsmann, A., Martin, E., van Meijgaard, E., Moseley, C., Pfeifer, S., Preuschmann, S., Radermacher, C., Radtke, K., Reich, D., Rounsevell, M., Samuelsson, P., Somot, S., Soussana, J.-F., Teichmann, C., Valentini, R., Vautard, R., Weber, B., Yiou, P., 2014. EURO-CORDEX: new high-resolution climate change projections for European impact research. *Reg. Environ. Change* 14, 563–578. <https://doi.org/10.1007/s10113-013-0499-2>.
- Jiménez-Martínez, J., García-Aróstegui, J., Hunin, J., Contreras, S., Baudron, P., Candela, L., 2016. The role of groundwater in highly human-modified hydrosystems: a review of impacts and mitigation options in the campo de Cartagena-Mar Menor coastal plain (SE Spain). *Environ. Rev.* 24, 377–392. <https://doi.org/10.1139/er-2015-0089>.
- Kang, Y., Khan, S., Ma, X., 2009. Climate change impacts on crop yield, crop water productivity and food security – A review. *Prog. Nat. Sci.* 19, 1665–1674. <https://doi.org/10.1016/j.pnsc.2009.08.001>.
- Koch, J., Wimmer, F., Schaldach, R., 2018. Analyzing the relationship between urbanization, food supply and demand, and irrigation requirements in Jordan. *Sci. Total Environ.* 636, 1500–1509. <https://doi.org/10.1016/j.scitotenv.2018.04.058>.
- Kok, K., Pedde, S., Gramberger, M., Harrison, P.A., Holman, I.P., 2019. New European socio-economic scenarios for climate change research: operationalising concepts to extend the shared socio-economic pathways. *Reg. Environ. Change* 19, 643–654. <https://doi.org/10.1007/s10113-018-1400-0>.
- Kuslu, Y., Dursun, A., Sahin, U., Kiziloglu, F.M., Turan, M., 2008. Short communication. Effect of deficit irrigation on curly lettuce grown under semiarid conditions. *Span. J. Agric. Res.* 6, 714–719. <https://doi.org/10.5424/sjar/2008064-367>.
- LamasRodríguez, M., GarciaLorenzo, M.L., MedinaMagro, M., PerezQuiros, G., 2023. Impact of climate risk materialization and ecological deterioration on house prices in Mar Menor, Spain. *Sci. Rep.* 13, 11772. <https://doi.org/10.1038/s41598-023-39022-8>.
- Leduc, C., Pulido-Bosch, A., Remini, B., 2017. Anthropization of groundwater resources in the Mediterranean region: processes and challenges. *Hydrogeol. J.* 25, 1529–1547. <https://doi.org/10.1007/s10040-017-1572-6>.
- Maeda, E.E., Pellikka, P.K., Clark, B.J., Siljander, M., 2011. Prospective changes in irrigation water requirements caused by agricultural expansion and climate changes in the eastern arc mountains of Kenya. *J. Environ. Manag.* 92, 982–993. <https://doi.org/10.1016/j.jenvman.2010.11.005>.
- Maetens, W., Vanmaerck, M., Poesen, J., Jankauskas, B., Jankauskiene, G., Ionita, I., 2012. Effects of land use on annual runoff and soil loss in Europe and the Mediterranean: a meta-analysis of plot data. *Prog. Phys. Geogr.* 36, 599–653. <https://doi.org/10.1177/0309133312451303>.
- Malek, K., Adam, J., Yoder, J., Givens, J., Stockle, C., Brady, M., Karimi, T., Rajagopalan, K., Liu, M., Reed, P., 2021. Impacts of irrigation efficiency on water-dependent sectors are heavily controlled by region-specific institutions and infrastructures. *J. Environ. Manag.* 300, 113731. <https://doi.org/10.1016/j.jenvman.2021.113731>.
- Malek, Z., Verburg, P.H., 2018. Adaptation of land management in the Mediterranean under scenarios of irrigation water use and availability. *Mitig. Adapt. Strategies Glob. Change* 23, 821–837. <https://doi.org/10.1007/s11027-017-9761-0>.
- Mariotti, A., Pan, Y., Zeng, N., Alessandri, A., 2015. Long-term climate change in the Mediterranean region in the midst of decadal variability. *Clim. Dyn.* 44, 1437–1456. <https://doi.org/10.1007/s00382-015-2487-3>.
- Martínez-Alvarez, V., García-Bastida, P.A., Martín-Gorriz, B., Soto-García, M., 2014. Adaptive strategies of on-farm water management under water supply constraints in south-eastern Spain. *Agric. Water Manag.* 136, 59–67. <https://doi.org/10.1016/j.agwat.2014.01.010>.
- Martin-Gorriz, B., Maestre-Valero, J.F., Almagro, M., Boix-Fayos, C., Martínez-Mena, M., 2020. Carbon emissions and economic assessment of farm operations under different tillage practices in organic rainfed almond orchards in semiarid Mediterranean conditions. *Sci. Hortic.* 261, 108978. <https://doi.org/10.1016/j.scienta.2019.108978>.
- McDermid, S., Nocco, M., Lawston-Parker, P., Keune, J., Pokhrel, Y., Jain, M., Jägermeyr, J., Brocca, L., Massari, C., Jones, A.D., Vahmani, P., Thiery, W., Yao, Y., Bell, A., Chen, L., Dorigo, W., Hanasaki, N., Jasechko, S., Lo, M.-H., Mahmood, R., Mishra, V., Mueller, N.D., Niyogi, D., Rabun, S.S., Sloat, L., Wada, Y., Zappa, L., Chen, F., Cook, B.I., Kim, H., Lombardozi, D., Polcher, J., Ryu, D., Santanello, J., Satoh, Y., Seneviratne, S., Singh, D., Yokohata, T., 2023. Irrigation in the Earth system. *Nat. Rev. Earth Environ.* <https://doi.org/10.1038/s43017-023-00438-5>.
- MedECC, Climate and Environmental Change in the Mediterranean Basin – Current Situation and Risks for the Future. First Mediterranean Assessment Report, Technical Report, MedECC, 2020.
- Merheb, M., Moussa, R., Abdallah, C., Colin, F., Perrin, C., Baghdadi, N., 2016. Hydrological response characteristics of Mediterranean catchments at different time scales: a meta-analysis. *Hydrol. Sci. J.* 61, 1–20. <https://doi.org/10.1080/02626667.2016.1140174>.
- Miceli, A., Vetrano, F., Torta, L., Esposito, A., Moncada, A., 2023. Effect of mycorrhizal inoculation on melon plants under deficit irrigation regimes. *Agronomy* 13, 440. <https://doi.org/10.3390/agronomy13020440>.
- Milano, M., Ruelland, D., Fernandez, S., Dezetter, A., Fabre, J., Servat, E., Fritsch, J.-M., Ardoin-Bardin, S., Thivet, G., 2013. Current state of Mediterranean water resources and future trends under climatic and anthropogenic changes. *Hydrol. Sci. J.* 58, 498–518. <https://doi.org/10.1080/02626667.2013.774458>.
- Ministerio de Fomento de España Plan Nacional de Ortofotografía Aérea, 2015.
- Mira-García, A.B., Romero-Trigueros, C., Gambín, J.M.B., Sánchez-Iglesias, M.D.P., Tortosa, P.A.N., Nicolás, E.N., 2023. Estimation of stomatal conductance by infra-red thermometry in citrus trees cultivated under regulated deficit irrigation and reclaimed water. *Agric. Water Manag.* 276, 108057. <https://doi.org/10.1016/j.agwat.2022.108057>.
- MITECO, Análisis de Soluciones Para El Vertido Cero al Mar Menor Proveniente Del Campo de Cartagena, Technical Report 07.803-0177/0411, MITECO, 2019.
- Mitter, H., Techen, A.-K., Sinabell, F., Helming, K., Schmid, E., Bodirsky, B.L., Holman, I., Kok, K., Lehtonen, H., Leip, A., LeMouél, C., Mathijs, E., Mehdi, B., Mittenzwei, K., Mora, O., Øistad, K., Øygarden, L., Priess, J.A., Reidsma, P., Schaldach, R., Schönhart, M., 2020. Shared socio-economic pathways for European agriculture and food systems: the Eur-Agri-SSPs. *Glob. Environ. Change* 65, 102159. <https://doi.org/10.1016/j.gloenvcha.2020.102159>.
- Morgan, R.P.C., Duzant, J.H., 2008. Modified MMF (Morgan–Morgan–Finney) model for evaluating effects of crops and vegetation cover on soil erosion. *Earth Surf. Process. Landf.* 33, 90–106. <https://doi.org/10.1002/esp.1530>.
- Morote, Á.-F., Olcina, J., Rico, A.-M., 2017a. Challenges and proposals for socio-ecological sustainability of the Tagus–segura aqueduct (Spain) under climate change. *Sustainability* 9, 2058. <https://doi.org/10.3390/su912058>.
- Morote, Á.-F., Rico, A.-M., Moltó, E., 2017b. Critical review of desalination in Spain: a resource for the future? desalination in Spain. *Geogr. Res.* 55, 412–423. <https://doi.org/10.1111/1745-5871.12232>.
- Mushtaq, S., Moghaddasi, M., 2011. Evaluating the potentials of deficit irrigation as an adaptive response to climate change and environmental demand. *Environ. Sci. Policy* 14, 1139–1150. <https://doi.org/10.1016/j.envsci.2011.07.007>.
- Nam, W.-H., Kim, T., Hong, E.-M., Choi, J.-Y., 2017. Regional climate change impacts on irrigation vulnerable season shifts in agricultural water availability for South Korea. *Water* 9, 735. <https://doi.org/10.3390/w9100735>.
- Nishizawa, T., Kay, S., Schuler, J., Klein, N., Conradt, T., Mielewicz, M., Herzog, F., Aurbacher, J., Zander, P., 2023. Towards diverse agricultural land uses: socio-ecological implications of European agricultural pathways for a Swiss orchard region. *Reg. Environ. Change* 23, 97. <https://doi.org/10.1007/s10113-023-02092-5>.
- Nunes, J.P., Jacinto, R., Keizer, J.J., 2017. Combined impacts of climate and socio-economic scenarios on irrigation water availability for a dry Mediterranean reservoir. *Sci. Total Environ.* 584–585, 219–233. <https://doi.org/10.1016/j.scitotenv.2017.01.131>.
- O'Neill, B.C., Carter, T.R., Ebi, K., Harrison, P.A., Kemp-Benedict, E., Kok, K., Kriegler, E., Preston, B.L., Riahi, K., Sillmann, J., van Ruijven, B.J., van Vuuren, D., Carlisle, D., Conde, C., Fuglestvedt, J., Green, C., Hasegawa, T., Leisinger, J., Monteith, S., Pichs-Madruga, R., 2020. Achievements and needs for the climate change scenario framework. *Nat. Clim. Change* 10, 1074–1084. <https://doi.org/10.1038/s41558-020-00952-0>.
- O'Neill, B.C., Kriegler, E., Ebi, K.L., Kemp-Benedict, E., Riahi, K., Rothman, D.S., van Ruijven, B.J., van Vuuren, D.P., Birkmann, J., Kok, K., Levy, M., Solecki, W., 2017. The roads ahead: narratives for shared socioeconomic pathways describing world futures in the 21st century. *Glob. Environ. Change* 42, 169–180. <https://doi.org/10.1016/j.gloenvcha.2015.01.004>.
- Panigrahi, P., 2023. Impact of deficit irrigation on citrus production under a sub-humid climate: a case study. *Water Supply* 23, 1177–1188. <https://doi.org/10.2166/ws.2023.074>.
- Patra, S.K., Poddar, R., Pramanik, S., Gaber, A., Hossain, A., 2022. Crop and water productivity and profitability of broccoli (*Brassica oleracea* L. var. *italica*) under gravity drip irrigation with mulching condition in a humid sub-tropical climate. *PLOS ONE* 17, e0265439. <https://doi.org/10.1371/journal.pone.0265439>.
- Pellicer-Martínez, F., Martínez-Paz, J.M., 2018. Probabilistic evaluation of the water footprint of a river basin: accounting method and case study in the Segura River Basin, Spain. *Sci. Total Environ.* 627, 28–38. <https://doi.org/10.1016/j.scitotenv.2018.01.223>.
- Peral García, C., Navascués Fernández-Victorio, B., Ramos Calzado, P., 2017. Serie de precipitación diaria en rejilla con fines climáticos. Agencia Estatal De Meteorol. ía. <https://doi.org/10.31978/014-17-009-5>.
- Poesen, J.W., van Wesemael, B., Bunte, K., Benet, A.S., 1998. Variation of rock fragment cover and size along semiarid hillslopes: a case-study from southeast Spain. *Geomorphology* 23, 323–335. [https://doi.org/10.1016/S0169-555X\(98\)00013-0](https://doi.org/10.1016/S0169-555X(98)00013-0).
- Pool, S., Francés, F., Garcia-Prats, A., Pulido-Velazquez, M., Sanchis-Ibor, C., Schirmer, M., Yang, H., Jiménez-Martínez, J., 2021. From flood to drip irrigation under climate change: impacts on evapotranspiration and groundwater recharge in the Mediterranean region of Valencia (Spain). *Earth's Future* 9. <https://doi.org/10.1029/2020EF001859>.
- Prosser, I.P., Rustomji, P., 2000. Sediment transport capacity relations for overland flow. *Prog. Phys. Geogr.* 24, 179–193. <https://doi.org/10.1177/030913330002400202>.

- Pulido-Velazquez, M., Peña-Haro, S., García-Prats, A., Mocholi-Almudever, A.F., Henriquez-Dole, L., Macian-Sorribes, H., Lopez-Nicolas, A., 2015. Integrated assessment of the impact of climate and land use changes on groundwater quantity and quality in the Mancha Oriental system (Spain). *Hydrol. Earth Syst. Sci.* 19, 1677–1693. <https://doi.org/10.5194/hess-19-1677-2015>.
- Qin, Y., Mueller, N.D., Siebert, S., Jackson, R.B., AghaKouchak, A., Zimmerman, J.B., Tong, D., Hong, C., Davis, S.J., 2019. Flexibility and intensity of global water use. *Nat. Sustain.* 2, 515–523. <https://doi.org/10.1038/s41893-019-0294-2>.
- Reimann, L., Merckens, J.-L., Vafeidis, A.T., 2018. Regionalized shared socioeconomic pathways: narratives and spatial population projections for the Mediterranean coastal zone. *Reg. Environ. Change* 18, 235–245. <https://doi.org/10.1007/s10113-017-1189-2>.
- Reimann, L., Vollstedt, B., Koerth, J., Tsakiris, M., Beer, M., Vafeidis, A.T., 2021. Extending the shared socioeconomic pathways (SSPs) to support local adaptation planning—A climate service for Flensburg, Germany. *Futures* 127, 102691. <https://doi.org/10.1016/j.futures.2020.102691>.
- Rey, D., Garrido, A., Mínguez, M.I., Ruiz-Ramos, M., 2011. Impact of climate change on maize's water needs, yields and profitability under various water prices in Spain. *Span. J. Agric. Res.* 9, 1047. <https://doi.org/10.5424/sjar/20110904-026-11>.
- Rocha, J., Carvalho-Santos, C., Diogo, P., Beça, P., Keizer, J.J., Nunes, J.P., 2020. Impacts of climate change on reservoir water availability, quality and irrigation needs in a water scarce Mediterranean region (southern Portugal). *Sci. Total Environ.* 736, 139477. <https://doi.org/10.1016/j.scitotenv.2020.139477>.
- Rohat, G., Wilhelm, O., Flacke, J., Monaghan, A., Gao, J., Dao, H., van Maarseveen, M., 2019. Characterizing the role of socioeconomic pathways in shaping future urban heat-related challenges. *Sci. Total Environ.* 695, 133941. <https://doi.org/10.1016/j.scitotenv.2019.133941>.
- Romero-Trigueros, C., Cabañero, J.J., Tortosa, P.A., Gambín, J.M., Maestre-Valero, J.F., Nicolás, E.N., 2020. Medium-long term effects of saline reclaimed water and regulated deficit irrigation on fruit quality of citrus. *J. Sci. Food Agric.* 100, 1350–1357. <https://doi.org/10.1002/jsfa.10091>.
- Rupérez-Moreno, C., Senent-Aparicio, J., Martínez-Vicente, D., García-Aróstegui, J.L., Calvo-Rubio, F.C., Pérez-Sánchez, J., 2017. Sustainability of irrigated agriculture with overexploited aquifers: the case of Segura basin (SE, Spain). *Agric. Water Manag.* 182, 67–76. <https://doi.org/10.1016/j.agwat.2016.12.008>.
- Sahin, U., Ekinci, M., Kiziloglu, F.M., Yildirim, E., Turan, M., Kotan, R., Ors, S., 2015. Ameliorative effects of plant growth promoting bacteria on water-yield relationships, growth, and nutrient uptake of lettuce plants under different irrigation levels. *HortScience* 50, 1379–1386. <https://doi.org/10.21273/HORTSCI.50.9.1379>.
- Savé, R., De Heralde, F., Aranda, X., Pla, E., Pascual, D., Funes, I., Biel, C., 2012. Potential changes in irrigation requirements and phenology of maize, apple trees and alfalfa under global change conditions in Fluvia watershed during XXIst century: results from a modeling approximation to watershed-level water balance. *Agric. Water Manag.* 114, 78–87. <https://doi.org/10.1016/j.agwat.2012.07.006>.
- Saxton, K.E., Rawls, W.J., 2006. Soil water characteristic estimates by texture and organic matter for hydrologic solutions. *Soil Sci. Soc. Am. J.* 70, 1569. <https://doi.org/10.2136/sssaj2005.0117>.
- Schwilch, G., Bachmann, F., Valente, S., Coelho, C., Moreira, J., Laouina, A., Chaker, M., Aderghal, M., Santos, P., Reed, M.S., 2012. A structured multi-stakeholder learning process for Sustainable Land Management. *J. Environ. Manag.* 107, 52–63. <https://doi.org/10.1016/j.jenvman.2012.04.023>.
- Sears, L., Caparelli, J., Lee, C., Pan, D., Strandberg, G., Vuu, L., Lin Lawell, C.-Y.C., 2018. Jevons' paradox and efficient irrigation technology. *Sustainability* 10, 1590. <https://doi.org/10.3390/su10051590>.
- Senent-Aparicio, J., López-Ballesteros, A., Cabezas, F., Pérez-Sánchez, J., Molina-Navarro, E., Modelling, A., 2021. Approach to forecast the effect of climate change on the tagus-segura interbasin water transfer. *Water Resour. Manag.* 35, 3791–3808. <https://doi.org/10.1007/s11269-021-02919-y>.
- Sese-Minguez, S., Boesveld, H., Asisn-Velis, S., van der Kooij, S., Maroulis, J., 2017. Transformations accompanying a shift from surface to drip irrigation in the canyoles watershed, Valencia, Spain. *Water Altern.* 10, 81–99.
- Soares, D., Rolim, J., Fradinho, M.J., Paço, T.A.D., 2020. Climate change impacts on irrigation requirements of preserved forage for horses under Mediterranean conditions. *Agronomy* 10, 1758. <https://doi.org/10.3390/agronomy10111758>.
- Soto-García, M., Martínez-Alvarez, V., García-Bastida, P.A., Alcon, F., Martín-Gorriç, B., 2013. Effect of water scarcity and modernisation on the performance of irrigation districts in south-eastern Spain. *Agric. Water Manag.* 124, 11–19. <https://doi.org/10.1016/j.agwat.2013.03.019>.
- E. Stehfest, D. van Vuuren, T. Kram, L. Bouwman, R. Alkemade, M. Bakkenes, H. Biemans, A. Bouwman, M. denElzen, J. Janse, P. Lucas, J. van Minnen, C. Müller, A. Prins, Integrated Assessment of Global Environmental Change with IMAGE 3.0 - Model Description and Policy Applications, Technical Report 735, PBL Netherlands Environmental Assessment Agency, The Hague, 2014.
- Switanek, M.B., Troch, P.A., Castro, C.L., Leuprecht, A., Chang, H.-I., Mukherjee, R., Demaria, E.M.C., 2017. Scaled distribution mapping: a bias correction method that preserves raw climate model projected changes. *Hydrol. Earth Syst. Sci.* 21, 2649–2666. <https://doi.org/10.5194/hess-21-2649-2017>.
- Tarjuelo, J.M., Rodríguez-Díaz, J.A., Abadía, R., Camacho, E., Rocamora, C., Moreno, M. A., 2015. Efficient water and energy use in irrigation modernization: lessons from Spanish case studies. *Agric. Water Manag.* 162, 67–77. <https://doi.org/10.1016/j.agwat.2015.08.009>.
- Tejero, I.G., Zuazo, V.H.D., Bocanegra, J.A.J., Fernández, J.L.M., 2011. Improved water-use efficiency by deficit-irrigation programmes: implications for saving water in citrus orchards. *Sci. Hortic.* 128, 274–282. <https://doi.org/10.1016/j.scienta.2011.01.035>.
- Terink, W., Lutz, A.F., Simons, G.W.H., Immerzeel, W.W., Droogers, P., 2015. SPHY v2.0: spatial processes in hydrology. *Geosci. Model Dev.* 8, 2009–2034. <https://doi.org/10.5194/gmd-8-2009-2015>.
- Thomas, B.F., Famiglietti, J.S., 2019. Identifying climate-induced groundwater depletion in GRACE observations. *Sci. Rep.* 9, 4124. <https://doi.org/10.1038/s41598-019-40155-y>.
- Uniyal, B., Dietrich, J., 2021. Simulation of irrigation demand and control in catchments – a review of methods and case studies. *Water Resour. Res.* 57, e2020WR029263. <https://doi.org/10.1029/2020WR029263>.
- de Vente, J., Reed, M.S., Stringer, L.C., Valente, S., Newig, J., 2016. How does the context and design of participatory decision making processes affect their outcomes? Evidence from sustainable land management in global drylands. *art24 Ecol. Soc.* 21. <https://doi.org/10.5751/ES-08053-210224>.
- Verweij, P., Cormont, A., Kok, K., Van Eupen, M., Janssen, S., Te Roller, J., De Winter, W., Pérez-Soba, M., Staritsky, I., 2018. Improving the applicability and transparency of land use change modelling: the iCLUE model. *Environ. Model. Softw.* 108, 81–90. <https://doi.org/10.1016/j.envsoft.2018.07.010>.
- Vogelsang, L.G., Weikard, H.-P., van Loon-Steensma, J.M., Bednar-Friedl, B., 2023. Assessing the cost-effectiveness of Nature-based Solutions under climate change uncertainty and learning. *Water Resour. Econ.* 43, 100224. <https://doi.org/10.1016/j.wre.2023.100224>.
- Von Gunten, D., Wöhling, T., Haslauer, C., Merchán, D., Causapé, J., Cirpka, O., 2015. Estimating climate-change effects on a Mediterranean catchment under various irrigation conditions. *J. Hydrol. Reg. Stud.* 4, 550–570. <https://doi.org/10.1016/j.ejrh.2015.08.001>.
- van Vuuren, D.P., Edmonds, J., Kainuma, M., Riahi, K., Thomson, A., Hibbard, K., Hurtt, G.C., Kram, T., Krey, V., Lamarque, J.F., Masui, T., Meinshausen, M., Nakicenovic, N., Smith, S.J., Rose, S.K., 2011. The representative concentration pathways: an overview. *Clim. Change* 109, 5–31. <https://doi.org/10.1007/s10584-011-0148-z>.
- Wada, Y., Van Beek, L.P.H., Van Kempen, C.M., Reckman, J.W.T.M., Vasak, S., Bierkens, M.F.P., 2010. Global depletion of groundwater resources. *Geophys. Res. Lett.* 37, L20402. <https://doi.org/10.1029/2010GL044571>.
- Wijngaard, R.R., Biemans, H., FriedrichLutz, A., BhaktaShrestha, A., Wester, P., Willem Immerzeel, W., 2018. Climate change vs. socio-economic development: understanding the future South Asian water gap. *Hydrol. Earth Syst. Sci.* 22, 6297–6321. <https://doi.org/10.5194/hess-22-6297-2018>.
- Xue, N., Lu, J., Gu, D., Lou, Y., Yuan, Y., Li, G., Kumagai, S., Saito, Y., Yoshioka, T., Zhang, N., 2023. Carbon footprint analysis and carbon neutrality potential of desalination by electro dialysis for different applications. *Water Res.* 232, 119716. <https://doi.org/10.1016/j.watres.2023.119716>.
- Zagaria, C., Schulp, C.J., Malek, Ž., Verburg, P.H., 2023. Potential for land and water management adaptations in Mediterranean croplands under climate change. *Agric. Syst.* 205, 103586. <https://doi.org/10.1016/j.agvsy.2022.103586>.
- Zhou, T., Wu, P., Sun, S., Li, X., Wang, Y., Luan, X., 2017. Impact of future climate change on regional crop water requirement—a case study of Hetao irrigation district, China. *Water* 9, 429. <https://doi.org/10.3390/w9060429>.